

JIS

JAPANESE INDUSTRIAL STANDARD

**Method of y-groove weld
cracking test**

JIS Z 3158^{—1993}

Translated and Published

by

Japanese Standards Association

**In the event of any doubt arising,
the original Standard in Japanese is to be final authority.**

1. Scope This Japanese Industrial Standard specifies the method of y-groove weld cracking test for detecting the cold cracking generated in the welds of the carbon steel and the low alloy steel by shielded metal arc welding, gas shielded arc welding and self-shielded arc welding.

Remarks: The standards cited in this Standard are shown in Attached Table 1.

2. Test plates

2.1 Shape and dimensions of test plates The shape and dimensions of the test plates shall conform to Fig. 1. The root gap " g " shall be determined by selecting the appropriate value in the range of 1.0 mm to 2.0 mm according to the welding method, the welding materials or the like, and its allowance shall be ± 0.2 mm.

Fig. 1. Shape and dimensions of test plates

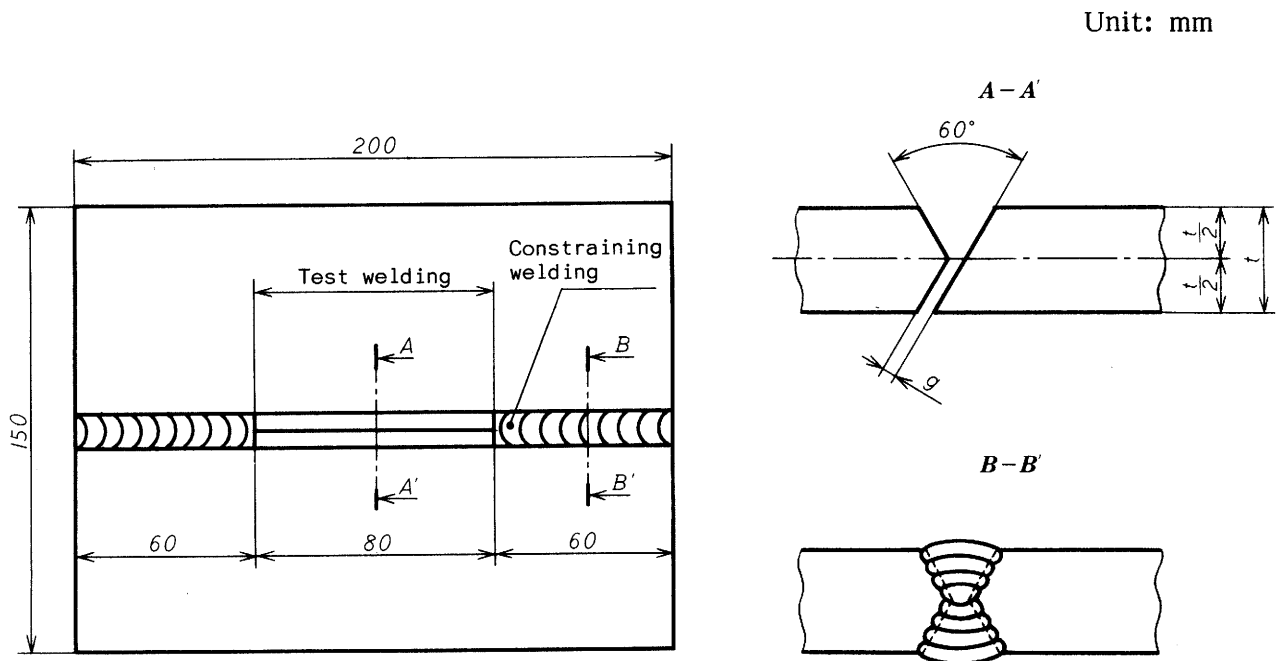

where, t : thickness of the test plate

g : root gap

2.2 Preparing method of test plates Preparation of groove shall be made by machine-cutting. The constraining welding shall be made from both sides by a suitable welding method, with care not to cause angular deformation and lack of penetration.