

JIS

JAPANESE
INDUSTRIAL
STANDARD

Translated and Published by
Japanese Standards Association

JIS A 5530 : 2015

(JISF)

Steel pipe sheet piles

ICS 77.140.75;93.020

Reference number : **JIS A 5530 : 2015 (E)**

A 5530 : 2015

Date of Establishment: 1983-11-01

Date of Revision: 2015-10-20

Date of Public Notice in Official Gazette: 2015-10-20

Investigated by: Japanese Industrial Standards Committee
Standards Board for ISO area
Technical Committee on Metal and Inorganic
Materials

JIS A 5530:2015, First English edition published in 2015-12

Translated and published by: Japanese Standards Association
Mita MT Building, 3-13-12, Mita, Minato-ku, Tokyo, 108-0073 JAPAN

In the event of any doubts arising as to the contents,
the original JIS is to be the final authority.

© JSA 2015

All rights reserved. Unless otherwise specified, no part of this publication may be reproduced or utilized in any form or by any means, electronic or mechanical, including photocopying and microfilm, without permission in writing from the publisher.

Printed in Japan

AT

PROTECTED BY COPYRIGHT

Contents

		Page
1	Scope	1
2	Normative references	2
3	Classification and symbols	3
4	Manufacturing method	3
5	Chemical composition	4
6	Mechanical properties	4
7	Shop circumferential welding	5
8	Materials of couplings and connecting couplings	5
9	Accessories, working and painting/coating	5
10	Shapes, dimensions, mass and tolerances	5
10.1	Edge shapes of steel pipe sheet pile	5
10.2	Shape of couplings and connecting couplings of steel pipe sheet pile	7
10.3	Dimensions and mass	8
10.4	Shape and dimensional tolerances of steel pipe sheet piles	11
10.5	Reinforcing band to be attached to steel pipe sheet piles	14
11	Appearance	14
12	Tests	14
12.1	Chemical analysis	14
12.2	Mechanical tests	14
12.3	Radiographic testing	16
13	Inspection and reinspection	16
13.1	Inspection	16
13.2	Reinspection	17
14	Marking	17
15	Report	17
	Annex A (informative) Typical examples of shapes and dimensions of accessories	18
	Annex B (informative) Typical examples of working and painting/coating	23

Foreword

This translation has been made based on the original Japanese Industrial Standard revised by the Minister of Economy, Trade and Industry, through deliberations at the Japanese Industrial Standards Committee as the result of proposal for revision of Japanese Industrial Standard submitted by The Japan Iron and Steel Federation (JISF) with the draft being attached, based on the provision of Article 12 Clause 1 of the Industrial Standardization Law applicable to the case of revision by the provision of Article 14.

Consequently **JIS A 5530:2010** is replaced with this Standard.

However, **JIS A 5530:2010** may be applied in the **JIS** mark certification based on the relevant provisions of Article 19 Clause 1, etc. of the Industrial Standardization Law until October 19, 2016.

This **JIS** document is protected by the Copyright Law.

Attention is drawn to the possibility that some parts of this Standard may conflict with patent rights, applications for a patent after opening to the public or utility model rights. The relevant Minister and the Japanese Industrial Standards Committee are not responsible for identifying any of such patent rights, applications for a patent after opening to the public or utility model rights.

Steel pipe sheet piles

1 Scope

This Japanese Industrial Standard specifies the steel pipe sheet piles²⁾ used for sheathing, coffering¹⁾, foundation of structures and the like. The construction of steel pipe sheet pile and the designation of each part are shown in Figure 1 to Figure 3.

NOTE : This Standard is applicable to steel pipe sheet piles of which the pipe body outside diameter is 500 mm to 2 000 mm.

Notes ¹⁾ Coffering refers to an enclosing wall intended for preventing water influx.

²⁾ A steel pipe sheet pile normally refers to a product consisting of a steel pipe body and couplings attached to it. Some products, however, are only pipe bodies with no couplings attached, depending on the using conditions or pipe body construction.

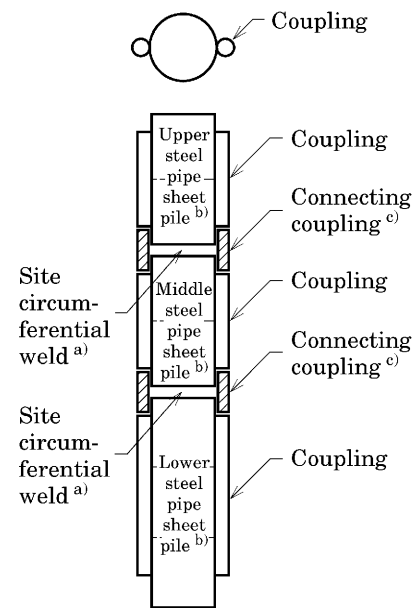
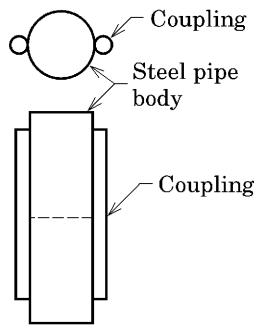
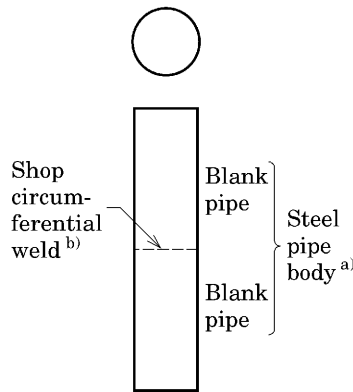

- Notes ^{a)} A steel pipe body refers to a blank pipe as it is or blank pipes jointed by shop circumferential welding (hereafter referred to as “jointed pipes”).
- ^{b)} The shop circumferential welding refers to circumferential welding performed by the manufacturer for connecting a blank pipe to another blank pipe to make a steel pipe body.

- Notes ^{a)} The site circumferential welding refers to circumferential welding of steel pipe body performed by the constructor for connecting a steel pipe sheet pile to another steel pipe sheet pile.
- ^{b)} In the steel pipe sheet piles which are connected on site, the piles in the upper, the middle and the lower positions are designated as the upper steel pipe sheet pile, the middle steel pipe sheet pile and the lower steel pipe sheet pile, respectively. When there are two or more middle steel pipe sheet piles, the one in the lowest shall be designated as the first middle steel pipe sheet pile, and the one in the second, as the second middle steel pipe sheet pile, and so on.
- ^{c)} The members used for connecting the couplings of the steel pipe sheet piles when connecting the steel pipe sheet piles on site are designated as the connecting couplings.

Figure 1
Constitution of steel pipe body and designation of each part

Figure 2
Constitution of steel pipe sheet pile and designation of each part

Figure 3
Constitution of steel pipe sheet piles connected on site and designation of each part

2 Normative references

The following standards contain provisions which, through reference in this text, constitute provisions of this Standard. The most recent editions of the standards (including amendments) indicated below shall be applied.

- JIS G 0320 *Standard test method for heat analysis of steel products*
- JIS G 0404 *Steel and steel products—General technical delivery requirements*
- JIS G 0415 *Steel and steel products—Inspection documents*
- JIS G 3101 *Rolled steels for general structure*
- JIS G 3192 *Dimensions, mass and permissible variations of hot rolled steel sections*
- JIS G 3193 *Dimensions, mass and permissible variations of hot rolled steel plates, sheets and strips*
- JIS G 3444 *Carbon steel tubes for general structure*
- JIS Z 2241 *Metallic materials—Tensile testing—Method of test at room temperature*
- JIS Z 3104 *Methods of radiographic examination for welded joints in steel*
- JIS Z 3121 *Methods of tensile test for butt welded joints*
- JIS Z 3211 *Covered electrodes for mild steel, high tensile strength steel and low temperature service steel*
- JIS Z 3312 *Solid wires for MAG and MIG welding of mild steel, high strength steel and low temperature service steel*
- JIS Z 3313 *Flux cored wires for gas shielded and self-shielded metal arc welding of mild steel, high strength steel and low temperature service steel*
- JIS Z 3351 *Solid wires for submerged arc welding of carbon steel and low alloy steel*
- JIS Z 3352 *Fluxes for submerged arc welding*
- JIS Z 8401 *Guide to the rounding of numbers*

3 Classification and symbols

The steel pipe sheet piles shall be classified into two grades, and symbols of grade shall be as given in Table 1.

Table 1 Symbol of grade

Symbol of grade
SKY400
SKY490

4 Manufacturing method

The manufacturing method shall be as follows.

- a) The blank pipe is produced by spiral seam welding or straight seam welding by arc welding or electric resistance welding.

In shop circumferential welding, the seam welds of the connected blank pipes shall be staggered at least 1/8 the pipe circumferential length in the circumferential direction.

- b) Steel pipe body is either a blank pipe as it is or a jointed pipe made by jointing blank pipes by shop circumferential welding. Jointed pipes may be manufactured by connecting blank pipes of different types or different wall thicknesses by shop circumferential welding.
- c) Steel pipe sheet pile shall be manufactured by welding couplings to a steel pipe body.

5 Chemical composition

The blank pipes shall be subjected to the chemical analysis of **12.1**, and the heat analysis values shall be as given in Table 2.

Table 2 Chemical composition

Unit: %

Symbol of grade	C	Si	Mn	P	S
SKY400	0.25 max.	—	—	0.040 max.	0.040 max.
SKY490	0.18 max.	0.55 max.	1.65 max.	0.035 max.	0.035 max.
If required, other alloy elements than those specified in the table may be added.					

6 Mechanical properties

The blank pipes shall be subjected to the mechanical tests of **12.2**, and the tensile strength, yield point or proof stress, elongation, tensile strength of welds and flattening resistance shall satisfy the requirements in Table 3. In the flattening resistance test, the test piece shall be free from cracks when flattened by compression until the distance between the flat plates specified in Table 3 is attained. The tensile strength of welds shall apply to the blank pipes manufactured by arc welding, and the flattening property shall apply to the blank pipes produced by electric resistance welding.

Table 3 Mechanical properties

Symbol of grade	Tensile strength N/mm ²	Yield point or proof stress N/mm ²	Elongation %		Tensile strength of weld N/mm ²	Flattening resistance Distance between flat plates mm
			Tensile test piece	Tensile test direction		
			Test piece No. 5	Normal to pipe axis ^{a)}		
SKY400	400 min.	235 min.	18 min.		400 min.	$\frac{2}{3} D$ ^{b)}
SKY490	490 min.	315 min.	18 min.		490 min.	$\frac{7}{8} D$ ^{b)}
NOTE : 1 N/mm ² = 1 MPa						
Notes ^{a)} When sample for tensile test is taken from a steel strip or steel sheet, the sampling direction shall be either in parallel or perpendicular to the rolling direction.						
^{b)} <i>D</i> is for outside diameter of pipe.						

7 Shop circumferential welding

The welding material for shop circumferential welding and the quality of welds shall be as follows.

- a) **Welding materials** The welding materials used for the shop circumferential welding to joint blank pipes to make a steel pipe body shall have a tensile strength equal or superior to the specified tensile strength for the blank pipe material and shall be any one or combination of materials specified in the following standards:

JIS Z 3211, JIS Z 3312, JIS Z 3313, JIS Z 3351, JIS Z 3352

Further, the welding material to be used for shop circumferential welding of different types of blank pipes shall have a tensile strength of 400 N/mm² or greater.

- b) **Quality of welds** Shop circumferential welds shall be subjected to the radiographic testing in **12.3**, and the observed flaws shall be classified one of the types given in Annex 4 Table 1 of **JIS Z 3104**, and fall under the category of Class 1 to Class 3 in the table applicable to their types given in clause **6** of Annex 4 in **JIS Z 3104**.

8 Materials of couplings and connecting couplings

The materials of the couplings and the connecting couplings for SKY400 and SKY490 shall be equal or superior in quality to either STK400 of **JIS G 3444** or SS400 of **JIS G 3101**. The welding materials to be used for fitting the couplings and connecting couplings shall have a tensile strength equal or superior to the specified tensile strength of the materials of the couplings and the connecting couplings, and shall conform to **7 a**).

9 Accessories, working and painting/coating

The purchaser may specify the attachment of accessories³⁾, working⁴⁾ and painting/coating to be performed on steel pipe sheet piles. Appearance, inspection, marking and so on in this case shall be as agreed between the purchaser and the manufacturer. In addition to the requirements specified in the main body of this Standard, typical shape and dimensions of accessories to be attached to the steel pipe body are shown in Annex A, and typical working and coating/painting to be performed on the steel pipe body are shown in Annex B.

Notes ³⁾ Accessories refers to the members temporarily required for the construction of steel pipe sheet pile.

⁴⁾ Working refers to the work performed on steel pipe sheet piles for the purpose of bringing out their performance such as load transmission to concrete.

10 Shapes, dimensions, mass and tolerances

10.1 Edge shapes of steel pipe sheet pile

The edge shapes of steel pipe sheet pile shall be as shown in Figure 4. Where the blank pipes of different wall thicknesses are connected, they shall normally have been worked at shop as shown in Figure 5. However, where a special reinforcement or working is required, it may be performed as agreed between the purchaser and the manufacturer.

NOTE : In Figure 4, head end face refers to the upper end of the steel pipe sheet pile, and bottom end face refers to its lower end.

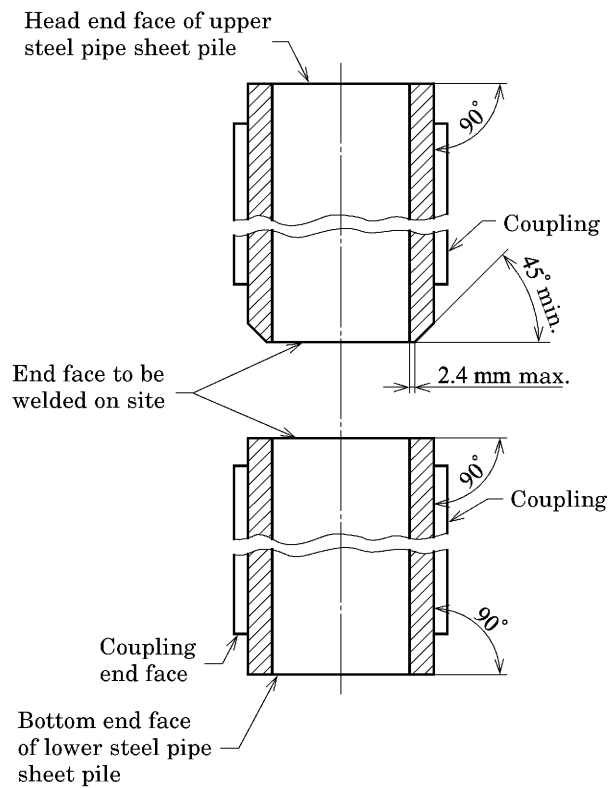
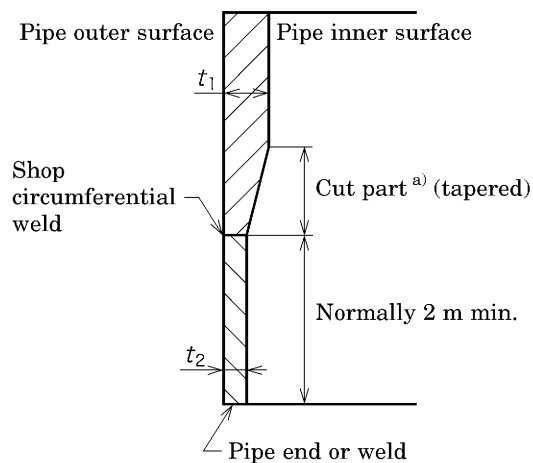

Figure 4 Shape of both ends and site circumferential welds of steel pipe sheet piles



Note ^{a)} The length of the part to be cut inside the pipe shall be not less than $4(t_1 - t_2)$. However, when $(t_1 - t_2)$ is 2 mm or less, whether or not the both-side welding is performed, or when $(t_1 - t_2)$ is 3 mm or less where the both-side welding is performed for the shop circumferential welds, cutting is unnecessary.

Figure 5 Shape of shop circumferential weld of blank pipes of different thicknesses

10.2 Shape of couplings and connecting couplings of steel pipe sheet pile

The shape of couplings and connecting couplings shall be as specified by the purchaser. Examples of shapes of coupling and connecting coupling are shown in Figure 6, and examples of their dimensions and unit mass, in Table 4.

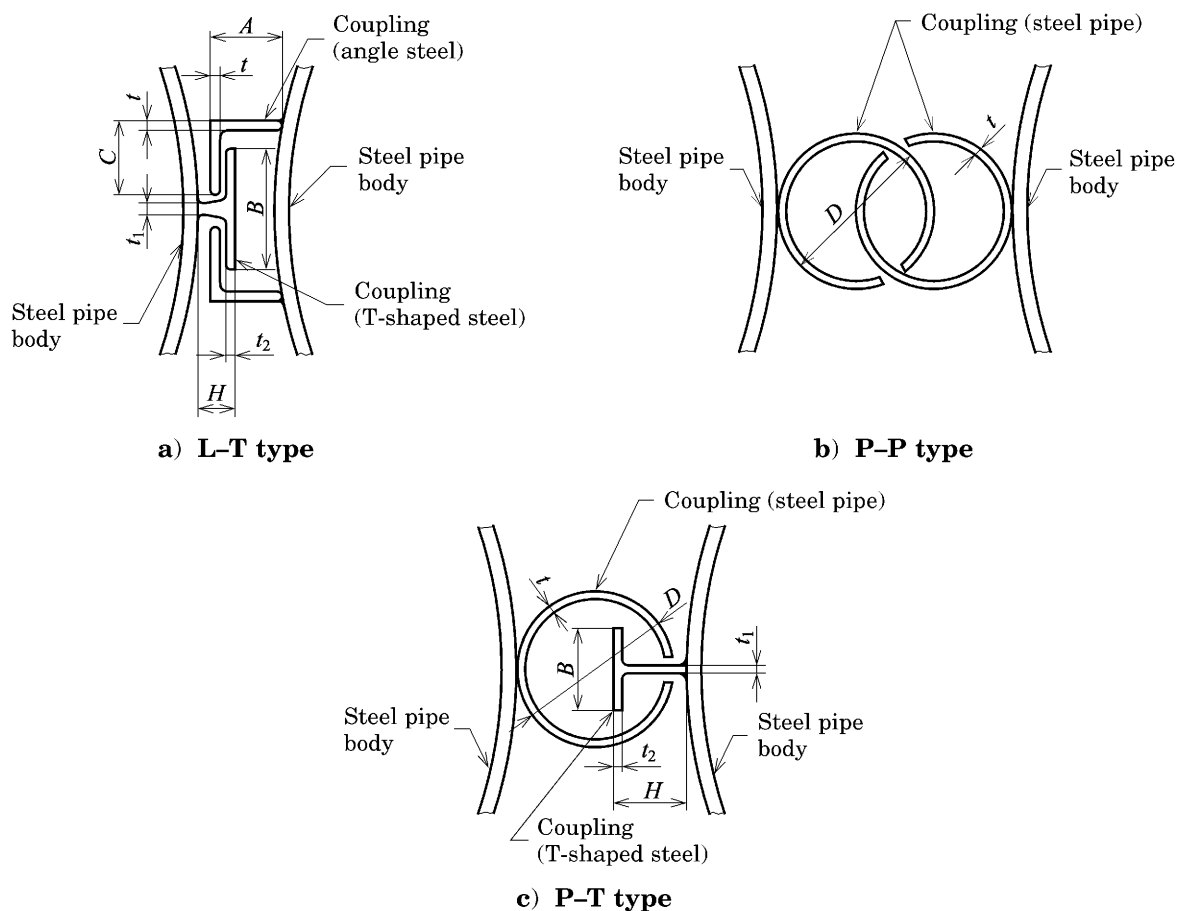

Figure 6 Examples of shapes of couplings and connecting couplings

Table 4 Examples of dimensions and unit mass of couplings and connecting couplings

Shape of coupling	Dimensions of coupling mm	Unit mass kg/m	Remarks
L-T type L : angle steel T : T-shaped steel	L : 65 × 65 × 8 T : 125 × 9 (× 39 × 12)	15.3 12.7	L : $A \times C \times t$ T : $B \times t_2 (\times H \times t_1)$
	L : 75 × 75 × 9 T : 125 × 9 (× 39 × 12)	19.9 12.7	
	L : 100 × 75 × 10 T : 125 × 9 (× 39 × 12)	26.0 12.7	
P-P type P : steel pipe	P : ϕ 165.2 × 9 P : ϕ 165.2 × 11	34.7 41.8	P : $D \times t$
P-T type P : steel pipe T : T-shaped steel	P : ϕ 165.2 × 9 T : 76 × 85 × 9 × 9	34.7 10.9	P : $D \times t$ T : $H \times B \times t_1 \times t_2$

10.3 Dimensions and mass

The dimensions and mass of steel pipe body, and mass of couplings shall be as follows. The mass of a steel pipe sheet pile shall be the total of the mass of the steel pipe body and that of couplings.

- a) The outside diameter, wall thickness, the sectional area, and the unit mass of the steel pipe body shall be as specified in Table 5. Upon agreement between the purchaser and the manufacturer, other dimensions than those specified in Table 5 may be used. In this case, the unit mass shall be obtained by the following formula assuming that the mass of 1 cm³ of steel is 7.85 g, and rounding off the result to three significant figures according to Rule A of **JIS Z 8401**. If the result exceeds 1 000 kg/m, the value shall be rounded to the four-digit integer.

$$W = 0.024\ 66t(D - t)$$

where, W : unit mass of pipe (kg/m)
 t : wall thickness of pipe (mm)
 D : outside diameter of pipe (mm)

0.024 66 : unit conversion coefficient for obtaining W

NOTE : The unit mass values given in Table 5 are the results of the calculation above.

For information, Table 5 shows the geometric moment of inertia, section modulus, radius of gyration of cross-section and outside surface area.

- b) Examples of unit mass of couplings are shown in Table 4.
c) The length of a blank pipe shall normally be 2 m or greater. The length of a steel pipe body shall normally be 6 m, or greater lengths in 0.5 m increments.

Table 5 Dimensions, cross-sectional area and unit mass of steel pipe body

Outside diameter	Wall thickness	Sectional area	Unit mass	Informative			
				Geometric moment of inertia	Section modulus	Radius of gyration of cross-section	Outside surface area
D mm	t mm	A cm ²	W kg/m	I cm ⁴	Z cm ³	i cm	m ² /m
500	9	138.8	109	418×10^2	167×10	17.4	1.57
	12	184.0	144	548×10^2	219×10	17.3	1.57
	14	213.8	168	632×10^2	253×10	17.2	1.57
508.0	9	141.1	111	439×10^2	173×10	17.6	1.60
	12	187.0	147	575×10^2	227×10	17.5	1.60
	14	217.3	171	663×10^2	261×10	17.5	1.60
600	9	167.1	131	730×10^2	243×10	20.9	1.88
	12	221.7	174	958×10^2	319×10	20.8	1.88
	14	257.7	202	111×10^3	369×10	20.7	1.88
	16	293.6	230	125×10^3	417×10	20.7	1.88

Table 5 (continued)

Outside diameter <i>D</i> mm	Wall thickness <i>t</i> mm	Sectional area <i>A</i> cm ²	Unit mass <i>W</i> kg/m	Informative			
				Geometric moment of inertia <i>I</i> cm ⁴	Section modulus <i>Z</i> cm ³	Radius of gyration of cross-section <i>i</i> cm	Outside surface area m ² /m
609.6	9	169.8	133	766×10^2	251×10	21.2	1.92
	12	225.3	177	101×10^3	330×10	21.1	1.92
	14	262.0	206	116×10^3	381×10	21.1	1.92
	16	298.4	234	132×10^3	431×10	21.0	1.92
700	9	195.4	153	117×10^3	333×10	24.4	2.20
	12	259.4	204	154×10^3	439×10	24.3	2.20
	14	301.7	237	178×10^3	507×10	24.3	2.20
	16	343.8	270	201×10^3	575×10	24.2	2.20
711.2	9	198.5	156	122×10^3	344×10	24.8	2.23
	12	263.6	207	161×10^3	453×10	24.7	2.23
	14	306.6	241	186×10^3	524×10	24.7	2.23
	16	349.4	274	211×10^3	594×10	24.6	2.23
800	9	223.6	176	175×10^3	437×10	28.0	2.51
	12	297.1	233	231×10^3	577×10	27.9	2.51
	14	345.7	271	267×10^3	668×10	27.8	2.51
	16	394.1	309	303×10^3	757×10	27.7	2.51
812.8	9	227.3	178	184×10^3	452×10	28.4	2.55
	12	301.9	237	242×10^3	596×10	28.3	2.55
	14	351.3	276	280×10^3	690×10	28.2	2.55
	16	400.5	314	318×10^3	782×10	28.2	2.55
900	12	334.8	263	330×10^3	733×10	31.4	2.83
	14	389.7	306	382×10^3	850×10	31.3	2.83
	16	444.3	349	434×10^3	965×10	31.3	2.83
	19	525.9	413	510×10^3	113×10^2	31.2	2.83
914.4	12	340.2	267	346×10^3	758×10	31.9	2.87
	14	396.0	311	401×10^3	878×10	31.8	2.87
	16	451.6	354	456×10^3	997×10	31.8	2.87
	19	534.5	420	536×10^3	117×10^2	31.7	2.87
1 000	12	372.5	292	455×10^3	909×10	34.9	3.14
	14	433.7	340	527×10^3	105×10^2	34.9	3.14
	16	494.6	388	599×10^3	120×10^2	34.8	3.14
	19	585.6	460	705×10^3	141×10^2	34.7	3.14
1 016.0	12	378.5	297	477×10^3	939×10	35.5	3.19
	14	440.7	346	553×10^3	109×10^2	35.4	3.19
	16	502.7	395	628×10^3	124×10^2	35.4	3.19
	19	595.1	467	740×10^3	146×10^2	35.3	3.19
1 100	14	477.6	375	704×10^3	128×10^2	38.4	3.46
	16	544.9	428	800×10^3	146×10^2	38.3	3.46
	19	645.3	506	943×10^3	171×10^2	38.2	3.46

Table 5 (concluded)

Outside diameter <i>D</i> mm	Wall thickness <i>t</i> mm	Sectional area <i>A</i> cm ²	Unit mass <i>W</i> kg/m	Informative			
				Geometric moment of inertia <i>I</i> cm ⁴	Section modulus <i>Z</i> cm ³	Radius of gyration of cross-section <i>i</i> cm	Outside surface area m ² /m
1 117.6	14	485.4	381	739×10 ³	132×10 ²	39.0	3.51
	16	553.7	435	840×10 ³	150×10 ²	39.0	3.51
	19	655.8	515	990×10 ³	177×10 ²	38.8	3.51
1 200	14	521.6	409	917×10 ³	153×10 ²	41.9	3.77
	16	595.1	467	104×10 ⁴	174×10 ²	41.9	3.77
	19	704.9	553	123×10 ⁴	205×10 ²	41.8	3.77
	22	814.2	639	141×10 ⁴	235×10 ²	41.7	3.77
1 219.2	14	530.1	416	963×10 ³	158×10 ²	42.6	3.83
	16	604.8	475	109×10 ⁴	180×10 ²	42.5	3.83
	19	716.4	562	129×10 ⁴	212×10 ²	42.4	3.83
	22	827.4	650	148×10 ⁴	243×10 ²	42.3	3.83
1 300	16	645.4	507	133×10 ⁴	205×10 ²	45.4	4.08
	19	764.6	600	157×10 ⁴	241×10 ²	45.3	4.08
	22	883.3	693	180×10 ⁴	278×10 ²	45.2	4.08
1 320.8	16	655.9	515	140×10 ⁴	211×10 ²	46.1	4.15
	19	777.0	610	165×10 ⁴	249×10 ²	46.0	4.15
	22	897.7	705	189×10 ⁴	287×10 ²	45.9	4.15
1 400	16	695.7	546	167×10 ⁴	238×10 ²	48.9	4.40
	19	824.3	647	197×10 ⁴	281×10 ²	48.8	4.40
	22	952.4	748	226×10 ⁴	323×10 ²	48.7	4.40
1 422.4	16	706.9	555	175×10 ⁴	246×10 ²	49.7	4.47
	19	837.7	658	206×10 ⁴	290×10 ²	49.6	4.47
	22	967.9	760	237×10 ⁴	334×10 ²	49.5	4.47
1 500	19	884.0	694	242×10 ⁴	323×10 ²	52.4	4.71
	22	1 021.5	802	279×10 ⁴	372×10 ²	52.3	4.71
	25	1 158.5	909	315×10 ⁴	420×10 ²	52.2	4.71
1 524.0	19	898.3	705	254×10 ⁴	334×10 ²	53.2	4.79
	22	1 038.1	815	293×10 ⁴	384×10 ²	53.1	4.79
	25	1 177.3	924	331×10 ⁴	434×10 ²	53.0	4.79
1 600	19	943.7	741	295×10 ⁴	369×10 ²	55.9	5.03
	22	1 090.6	856	340×10 ⁴	424×10 ²	55.8	5.03
	25	1 237.0	971	384×10 ⁴	480×10 ²	55.7	5.03
1 625.6	19	959.0	753	309×10 ⁴	381×10 ²	56.8	5.11
	22	1 108.3	870	356×10 ⁴	438×10 ²	56.7	5.11
	25	1 257.1	987	403×10 ⁴	495×10 ²	56.6	5.11
1 800	22	1 228.9	965	486×10 ⁴	540×10 ²	62.9	5.65
	25	1 394.1	1 094	549×10 ⁴	610×10 ²	62.8	5.65
2 000	22	1 367.1	1 073	669×10 ⁴	669×10 ²	69.9	6.28
	25	1 551.2	1 218	756×10 ⁴	756×10 ²	69.8	6.28

10.4 Shape and dimensional tolerances of steel pipe sheet piles

The shape and dimensional tolerances of steel pipe sheet piles shall be as follows. For steel pipe sheet piles with an outside diameter less than 500 mm or exceeding 2 000 mm or t/D (wall thickness/outside diameter) less than 1.1 %, these requirements shall be as agreed between the purchaser and the manufacturer.

- a) The shape and dimensional tolerances of steel pipe sheet pile shall be as specified in Table 6.
- b) In the case of site circumferential welding, linear misalignment⁵⁾ in connecting two steel pipe sheet piles (hereafter referred to as “linear misalignment in site circumferential weld”) shall be within the allowable tolerance given in Table 7.

Note⁵⁾ Linear misalignment is the difference in the pipe end outside diameter (peripheral length conversion value) between two steel pipe bodies to be connected by site circumferential welding.

Table 6 Shape and dimensional tolerances of steel pipe sheet piles

Division		Tolerance	Remarks
Outside diameter ^{a)} (<i>D</i>)	Pipe end	±0.5 %	Tolerance on outside diameter basically applies to the measured peripheral length. The formula for conversion between outside diameter (<i>D</i>) and peripheral length (<i>l</i>) is as given below. $D = l/\pi$ where, <i>D</i> : outside diameter (mm), <i>l</i> : peripheral length (mm) $\pi = 3.141\ 6$
Width (<i>W</i>)	<i>t/D</i> 1.1 % or over to and excl. 1.5 %	±2.0 %	
	<i>t/D</i> 1.5 % or over	±1.5 %	
Wall thickness ^{a)} (<i>t</i>)	Wall thickness under 16 mm	Outside diameter 500 mm or over to and excl. 800 mm	+Not specified −0.7 mm
		Outside diameter 800 mm or over up to and incl. 2 000 mm	+Not specified −0.8 mm
	Wall thickness 16 mm or over	Outside diameter 500 mm or over to and excl. 800 mm	+Not specified −0.8 mm
		Outside diameter 800 mm or over up to and incl. 2 000 mm	+Not specified −1.0 mm
Length ^{b)} (<i>L</i>), (<i>l</i>)	Steel pipe body (<i>L</i>)	+Not specified 0	
	Coupling (<i>l</i>)		
Flexure ^{c)} (<i>M</i>)			0.1 % max. of the length of steel pipe body (<i>L</i>) If the length of steel pipe body is less than 6 m, 6 mm max.
			
Camber ^{d)} (<i>S</i>)			0.1 % max. of the length of steel pipe body (<i>L</i>) If the length of the steel pipe body is less than 6 m, 6 mm max.
			

Table 6 (concluded)

Division			Tolerance	Remarks
Straightness of the opening of coupling ^{d)} (<i>P</i>)	Length of coupling (<i>l</i>) 15 m or under		10 mm max.	
	Length of coupling (<i>l</i>) over 15 m		$\frac{1}{1500}$ max. of the length of coupling (<i>l</i>)	
Attaching position of coupling (\hat{Q})	Pipe end		5 mm max. ^{e)}	
Flatness of the end face to be welded on site	Steel pipe body (<i>h</i>)		2 mm max.	
	Coupling (<i>h'</i>)			
Perpendicularity of the end face to be welded on site	Steel pipe body (<i>C</i>)	Outside diameter 1 000 mm or under	Length of steel pipe body 18 m or under	
			Length of steel pipe body over 18 m	
		Outside diameter over 1 000 mm	0.5 % max. of outside diameter, not exceeding 3 mm	
	Coupling (<i>C'</i>)		2 mm max.	
<p>The figures in this table, though presenting the case of P-P type, apply to all other types of couplings.</p> <p>Notes</p> <p>a) The outside diameter and wall thickness values apply to those of a steel pipe body.</p> <p>b) For tolerance on length, “+ not specified, -50 mm” may be applied upon agreement between the purchaser and the manufacturer.</p> <p>c) The flexure shall be measured at a position close to the coupling and at either convex or concave.</p> <p>d) The camber and straightness of the opening of coupling shall be measured at either convex or concave.</p> <p>e) The value applies to the circumferential distance between the specified attaching position and the actual attaching position.</p>				

Table 7 Tolerance on linear misalignment of site circumferential welds ^{a)}

Unit: mm

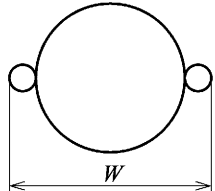
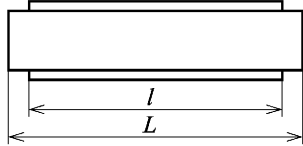
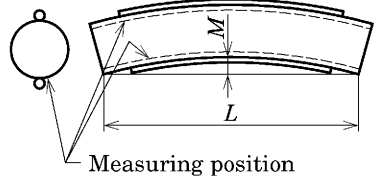
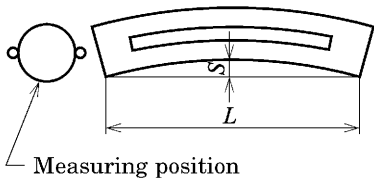
Division of outside diameter	Tolerance
500 or over to and excl. 700	2 max.
700 or over up to and incl. 1 016	3 max.
Over 1 016 up to and incl. 2 000	4 max.
<p>Linear misalignment is the difference in the pipe end outside diameter (peripheral length conversion value) between two pipe bodies to be connected by site circumferential welding. It is obtained as the difference in outside diameter which has been converted from the peripheral length through division by π, where, $\pi=3.1416$.</p> <p>Note ^{a)} If combination of a part/all of the piles to be connected is to be determined in advance for the purpose of conforming to the above tolerance, the steel pipe sheet piles to be connected shall be marked with numbers or symbols for clarifying the combination upon agreement between the purchaser and the manufacturer.</p>	

10.5 Reinforcing band to be attached to steel pipe sheet piles

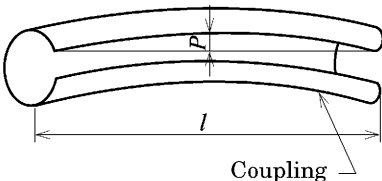
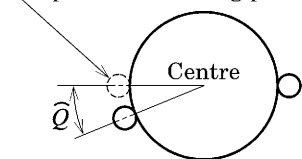
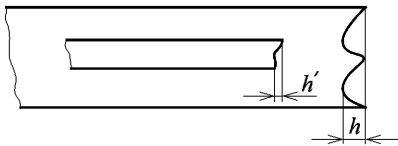
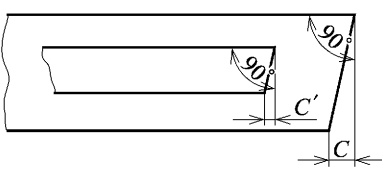
For steel pipe sheet piles with t/D less than 1.1 %, a reinforcing band shall be attached to the inside of the pipe end to be welded on site for prevention of deformation. Examples of reinforcing band for prevention of deformation are shown in **A.4.1** for reference.

11 Appearance

The steel pipe sheet piles shall be free from defects detrimental to use. However, surface defects detrimental to use may be treated by grinding or repaired by welding in accordance with clause **9** of **JIS G 3192** for couplings (angle shape) and couplings (T-shaped steel), and in accordance with clause **7** of **JIS G 3193** for steel pipe bodies and couplings (steel pipe).

12 Tests

12.1 Chemical analysis

12.1.1 General requirements and sampling method

General requirements for chemical analysis and sampling method shall be in accordance with clause **8** of **JIS G 0404**.

12.1.2 Analysis method

The heat analysis method shall be in accordance with **JIS G 0320**.

12.2 Mechanical tests

12.2.1 General

General requirements for mechanical tests shall be in accordance with clauses **7** and **9** of **JIS G 0404**. However, the sampling method for mechanical tests shall be in accordance with Class A in **7.6** of **JIS G 0404**.

12.2.2 Sampling method and number of test pieces

The sampling method and the number of test pieces to be taken from each sample shall be in accordance with Table 8.

12.2.3 Tensile test

The tensile test shall be performed on the base metal of blank pipe and on seam weld of arc welded pipe.

a) **Test piece** The test piece shall be as follows.

- 1) The tensile test piece shall be Test piece No. 5 specified in **JIS Z 2241**, and the sampling procedure shall be in accordance with either of the following:
 - for blank pipes not formed by expansion, take the test piece from the pipe, or the steel strip or steel plate to be used for the manufacture of the pipe;
 - for blank pipes formed by expansion, take the test piece from the pipe.
- 2) The weld tensile test piece of arc welded steel pipe shall be Test piece No. 1 in **JIS Z 3121**, and taken either from the blank pipe, or from a sample pipe whose end has been welded under the same conditions as the blank pipe.

b) **Test method** The test method shall be as specified in **JIS Z 2241**.

Table 8 Sampling method and number of test pieces

Division	Sampling method		Number of test pieces to be taken from one sample
In the case of taking the sample from blank pipe	Take one sample from each 1 250 m length or its fraction of blank tubes of the same dimensions ^{a)} .		Tensile test piece: one Weld tensile test piece: one Flattening test piece: one
In the case of taking the sample for tensile test from steel plates or steel strips	Steel plate	Take one sample from each unit of steel plates belonging to the same heat, of which the maximum thickness is not more than twice the minimum thickness. For a unit exceeding 50 t in mass, take one sample from each of the two sample products.	Tensile test piece: one
	Steel strip	Take one sample from each unit of steel strips belonging to the same heat and having the same thickness. For a unit exceeding 50 t in mass, take one sample from each of the two sample products.	
In the case of taking a weld tensile test piece from a sample taken from the end of a straight seam welded steel pipe which has been welded under the same conditions as the blank pipe.	Take one sample from every unit of blank pipes of the same dimensions ^{a)} equivalent to 1 250 m length or its fraction.		Weld tensile test piece: one
NOTE : See clause 6 for application of test items.			
Note ^{a)} Same dimensions refer to the same outside diameter and the same wall thickness.			

12.2.4 Flattening test

The flattening test shall be as follows.

- a) **Test piece** The test piece for the flattening test of electric resistance welded steel pipe shall be 50 mm or over in length.
- b) **Test method** Place a test piece, at the ordinary temperature (5 °C to 35 °C), between two flat plates and compress until the distance (H) between the flat plates is equal to or less than the value given in Table 3. Examine the flattened test piece for cracks. The test piece shall be placed as shown in Figure 7 so that the line connecting the centre of the pipe and the weld is perpendicular to the direction of compression.

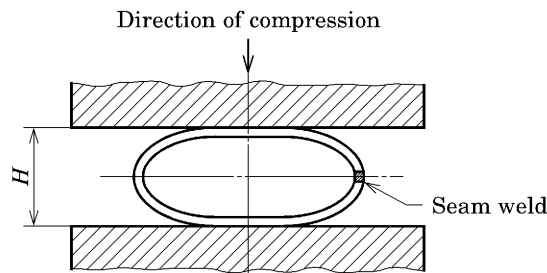

Figure 7 Flattening test

12.3 Radiographic testing

The radiographic testing to be performed on shop circumferential weld shall be as follows.

- a) **Test frequency and test position** Test one in every 10 shop circumferential welds and its fractions having been welded under the same conditions and having the same dimensions, and take a radiograph, one per weld, of the crossing point of the seam weld and shop circumferential weld.
- b) **Test method** The test method shall be as specified in **JIS Z 3104**.

13 Inspection and reinspection

13.1 Inspection

The inspection shall be as follows.

- a) General requirements for inspection shall be as specified in **JIS G 0404**.
- b) The chemical composition of blank pipes shall conform to the requirements of clause 5.
- c) The mechanical properties of blank pipes shall conform to the requirements of clause 6.
- d) Site circumferential welding shall conform to the requirements of clause 7.
- e) The shape and dimensions of steel pipe sheet pile, which is inspected for each pile, shall conform to the requirements of clause 10.

- f) The appearance of steel pipe sheet pile, which is inspected for each pile, shall conform to the requirements of clause **11**.

13.2 Reinspection

The blank pipes having failed in the tensile test or flattening test may be subjected to the retest according to **9.8** of **JIS G 0404** for further acceptance judgement.

14 Marking

The steel pipe sheet piles accepted by the inspection shall be marked indelibly with the following information.

The order of markings is not specified.

When blank pipes of different classes or different dimensions are jointed to make a steel pipe body, all relevant classes or dimensions of the blank pipes shall be marked.

- a) Symbol of grade
- b) Manufacturer's name or its identifying brand
- c) Serial number
- d) Dimensions (outside diameter, wall thickness, and length)

15 Report

The manufacturer shall submit the inspection document to the purchaser. The report shall be in accordance with clause **13** of **JIS G 0404**. Unless otherwise specified in the order, the type of the inspection document to be submitted shall be the standard designation 3.1 in Table 1 of **JIS G 0415**. For dimensions, the inspection result of one for every 10 or its fraction of steel pipe sheet piles shall be reported.

When alloy element(s) other than those in Table 2 is/are added, the content of added element(s) shall be reported in the inspection certificate.

Annex A (informative)

Typical examples of shapes and dimensions of accessories

A.1 Scope

This Annex is for showing typical examples of shapes, dimensions and other matters of accessories attached to the steel pipe bodies if specified by the purchaser, and does not constitute a part of the provisions of this Standard.

A.2 Materials of accessories and welding materials

The materials of accessories shall have mechanical properties equal to or better than SS400 of **JIS G 3101**, and welding materials used to attach the accessories shall be in accordance with any one of the following standards so that the specified tensile strength for accessories can be obtained:

JIS Z 3211, JIS Z 3312, JIS Z 3313, JIS Z 3351, JIS Z 3352

When the blank pipe and accessory are not of the same strength, the welding material to be used shall satisfy the lower tensile strength requirement of the two.

A.3 Appearance, inspection and marking of accessories

The appearance, inspection and marking of accessories shall be as follows.

- a) **Appearance** The appearance of accessories shall be free from defects detrimental to use.
- b) **Inspection** The materials and welds of accessories shall be in accordance with **A.2**. The appearance, when visually observed, shall conform to the requirements given in **a**).
- c) **Marking** The accessories not attached to the main body at shop shall be given markings of class and dimensions so that they can be properly identified. The accessories attached to the main body at shop are not marked with class or dimensions.

A.4 Examples of shapes and dimensions of accessories

A.4.1 Reinforcing band

A.4.1.1 Shape

Reinforcing bands include outer surface reinforcing bands to attach to the outer surface of the bottom of the steel pipe or reinforcing bands for prevention of deformation to attach to the inner surface of the head and bottom of the steel pipe. Examples of shape and dimensions of the outer surface reinforcing band are shown in Figure A.1, and those of reinforcing band for prevention of deformation, in Figure A.2.

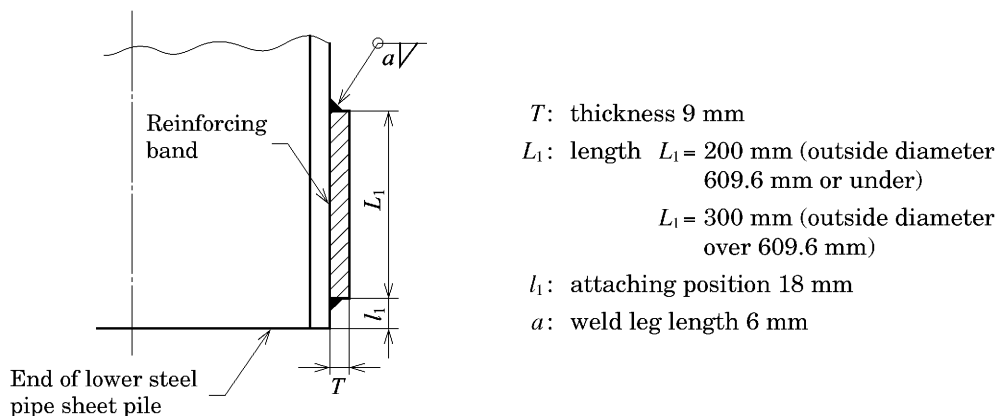

Figure A.1 Example of shape and dimensions of outer surface reinforcing band

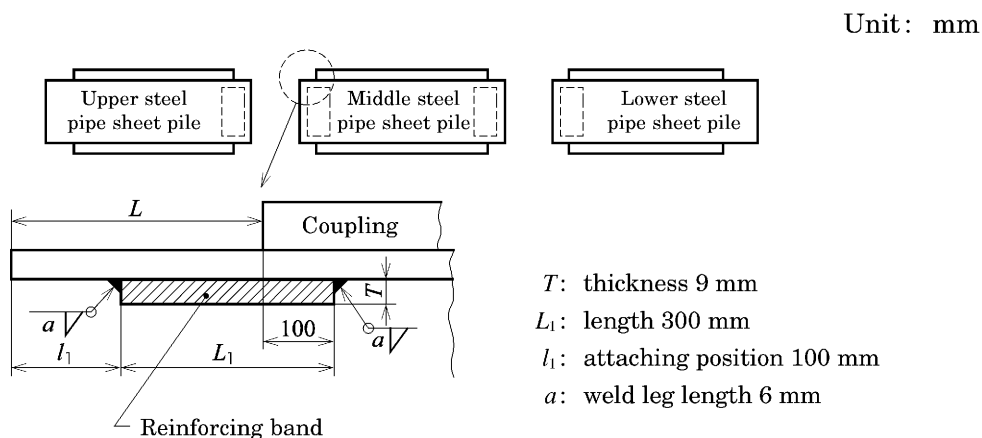

Figure A.2 Example of shape and dimensions of reinforcing band for prevention of deformation

A.4.1.2 Dimensional tolerances

The dimensional tolerances for reinforcing bands shall be as given in Table A.1.

Table A.1 Dimensional tolerances for reinforcing bands

Division	Thickness T	Length L_1	Attaching position l_1
Dimensional tolerances	+Not specified -0.9 mm	+Not specified -5 mm	0 -9 mm

A.4.2 Lifting lug

Examples of shape and dimensions of lifting lug are shown in Table A.2.

Table A.2 Example of shape and dimensions of lifting lug

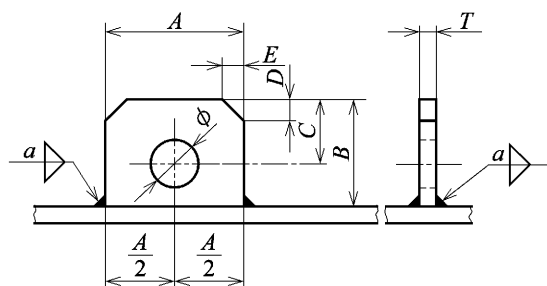

Unit: mm

Maximum lifting load t (tons)	Width A	Height B	Hole position C	Chamfer dimension		Board thickness T	Hole diameter ϕ	Weld leg length a
				D	E			
3 or under	120	100	55	25	25	12	40	6
Over 3 up to and incl. 5	120	100	55	25	25	16	40	9
Over 5 up to and incl. 10	200	150	90	30	30	22	65	15
Over 10 up to and incl. 20	300	250	150	50	50	22	80	15

A.4.3 Backing ring and stopper

When a stopper is attached to the backing ring of site circumferential weld of steel pipe body, middle steel pipe sheet pile, or lower steel pipe sheet pile, the shape and dimensions of backing ring and stopper shall be as shown in Figure A.3 as a rule.

Unit: mm

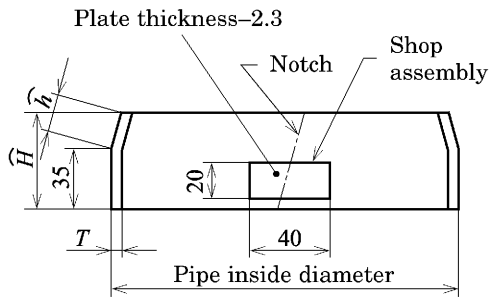

Unit: mm

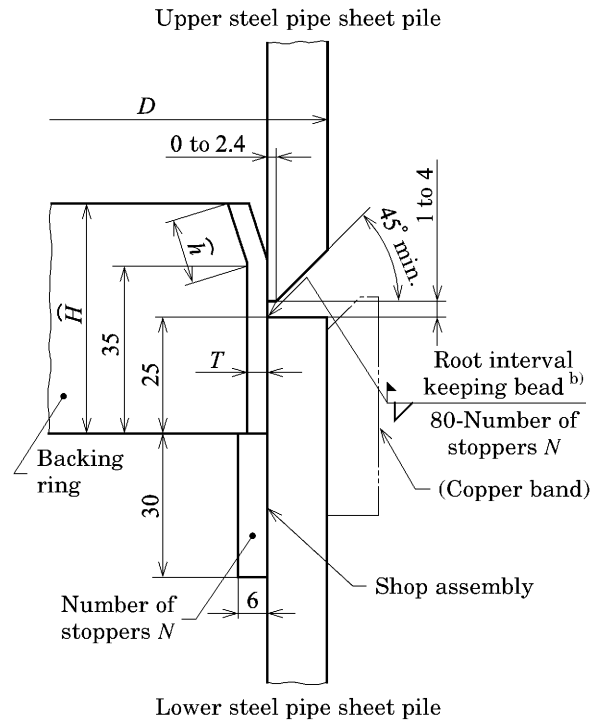

Note ^{b)} The spacer may be used instead of the root interval keeping bead.

Thickness and height of backing ring

Outside diameter D (mm)	T	\widehat{H}	\widehat{h}
1 016 or under	4.5	$\widehat{50}$	$\widehat{15}$, in the case of $\widehat{H} = \widehat{50}$
Over 1 016	6.0	$\widehat{70}, \widehat{50}^a)$	$\widehat{35}$, in the case of $\widehat{H} = \widehat{70}$
Note ^{a)} $\widehat{50}$ mm shall be applied in the case of pile installation by inner excavation.			

a) Backing ring

Number of stoppers

Outside diameter D (mm)	Number N
609.6 or under	4
Over 609.6 up to and incl. 1 016	6
Over 1 016	8

b) Backing ring and stopper

Figure A.3 Example of shape and dimensions of backing ring and stopper

A.4.4 Auxiliary parts for execution

The auxiliary parts for execution, typically made of high-strength steel, are attached to the bottom of the lower steel pipe sheet pile as shown in Figure A.4 to enhance the penetration ability and to prevent the damage of the bottom of the lower steel pipe sheet pile during the penetration.

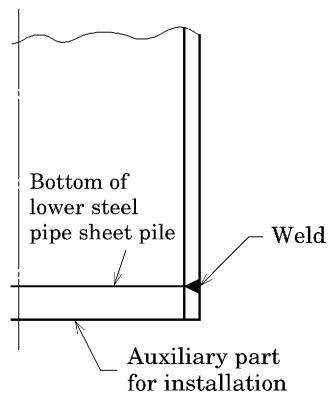

Figure A.4 Example of attachment of auxiliary part for execution

Annex B (informative)

Typical examples of working and painting/coating

B.1 Scope

This Annex is for showing typical examples of working and painting/coating to be performed on steel pipe bodies if specified by the purchaser, and does not constitute a part of the provisions of this Standard.

B.2 Types of working

Typical examples of working to be performed on steel pipe body are shown in Table B.1.

Table B.1 Typical examples of working

Type of working	Details of working	Typical shape illustrated in:
Fitting of bearing members ^{a)} or ribband ^{b)}	1) Ring type flat bars, steel bars, weld beads or ribs of steel plate are attached to the inner or outer surface of the steel pipe body [a) to d) of Figure B.1]. 2) Ribbands are attached to the inner and/or outer surface of the top of steel pipe body.	Figure B.1
Fitting of mechanical joints	As an alternative to welding on site, the mechanical joints are welded to the ends of the steel pipe body.	Figure B.2
Notes ^{a)} The bearing member is a part to transfer the load by bearing stress (compression stress working on a partial area in a certain whole area) to concrete or cement mortar. ^{b)} The ribband is a bearing member which is attached to either or both of the inner and outer surfaces of the head of the steel pipe body for ensuring the transfer of axial direction force of steel pipe body to concrete.		

B.3 Welding materials

Welding materials used for working shall be any one or combination of the materials specified in the following standards, unless otherwise specified:

JIS Z 3211, JIS Z 3312, JIS Z 3313, JIS Z 3351, JIS Z 3352

When the members installed in working and blank pipe are not of the same strength, the welding material to be used shall satisfy at least the lower tensile strength requirement of the two.

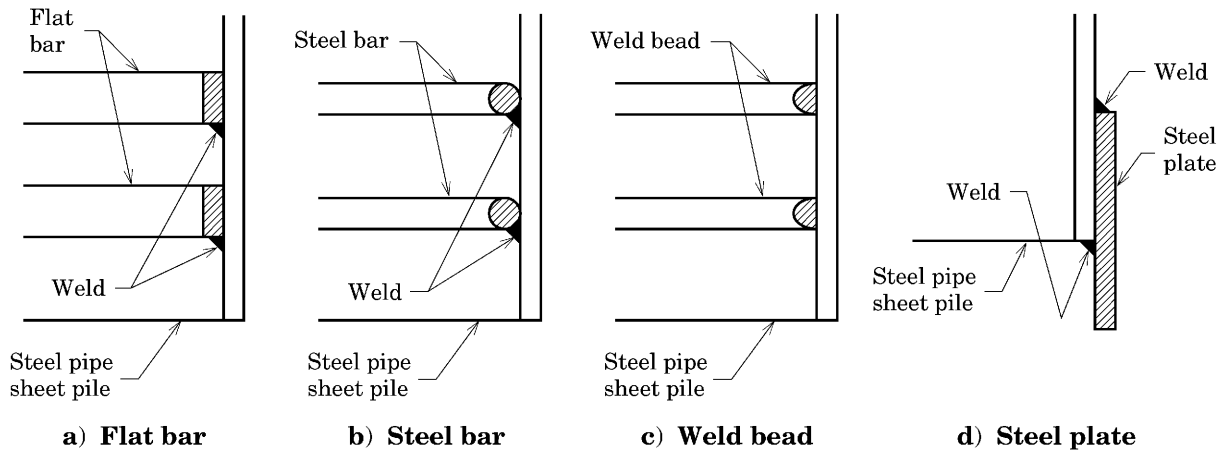

Figure B.1 Examples of types of bearing member

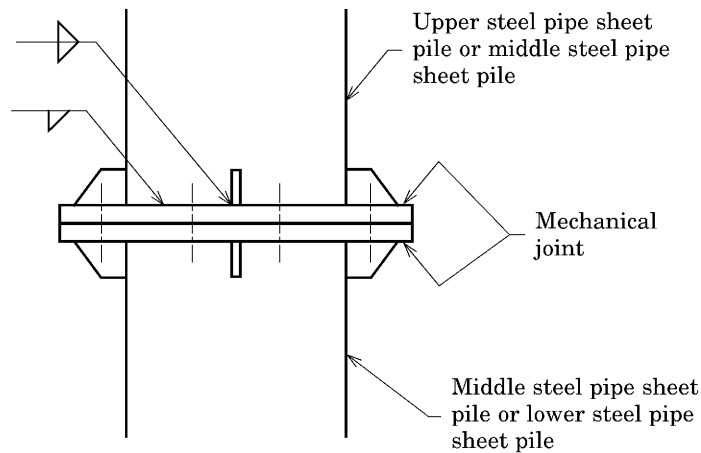

Figure B.2 Example of shape of mechanical joint

B.4 Appearance, inspection and report of parts used for working

The appearance, inspection and report of parts used for working shall be as follows.

- a) **Appearance** The appearance of parts used for working shall be free from defects detrimental to use.
- b) **Inspection** The appearance of parts used for working, when visually inspected, shall conform to the requirements given in a).
- c) **Report** If requested by the purchaser, the manufacturer shall submit the inspection document to the purchaser. The report shall be in accordance with clause 13 of **JIS G 0404**. Unless otherwise specified in the order, the type of the inspection document to be submitted shall be the standard designation 3.1 in Table 1 of **JIS G 0415**.

B.5 Type of painting/coating and appearance

B.5.1 Type of painting/coating

The typical types of painting/coating on steel pipe sheet piles are shown in Table B.2.

Table B.2 Type of painting/coating

Use	Division	Type
Rust prevention	Painting	Inorganic zinc-rich + epoxy resin paint
		Inorganic zinc-rich + tar epoxy resin paint
		Paint with glass flake
	Heavy-duty rust prevention coating	Urethane elastomer coating

B.5.2 Appearance

The appearance of painting/coating, when visually inspected, shall be free from defects detrimental to use.

Errata for JIS (English edition) are printed in *Standardization and Quality Control*, published monthly by the Japanese Standards Association, and also provided to subscribers of JIS (English edition) in *Monthly Information*.

Errata will be provided upon request, please contact:

Publishing Group, Japanese Standards Association

Mita MT Building, 3-13-12, Mita, Minato-ku, Tokyo, 108-0073 JAPAN

TEL. 03-4231-8550 FAX. 03-4231-8665