

# INTERNATIONAL STANDARD

---

**Connectors for electrical and electronic equipment – Product requirements –  
Part 3-119: Rectangular connectors – Detail specification for shielded and  
unshielded, free and fixed 10-way connectors with push-pull coupling for  
industrial environments for data transmission with frequencies  
up to 100 MHz**



## THIS PUBLICATION IS COPYRIGHT PROTECTED

Copyright © 2017 IEC, Geneva, Switzerland

All rights reserved. Unless otherwise specified, no part of this publication may be reproduced or utilized in any form or by any means, electronic or mechanical, including photocopying and microfilm, without permission in writing from either IEC or IEC's member National Committee in the country of the requester. If you have any questions about IEC copyright or have an enquiry about obtaining additional rights to this publication, please contact the address below or your local IEC member National Committee for further information.

IEC Central Office  
3, rue de Varembe  
CH-1211 Geneva 20  
Switzerland

Tel.: +41 22 919 02 11  
Fax: +41 22 919 03 00  
[info@iec.ch](mailto:info@iec.ch)  
[www.iec.ch](http://www.iec.ch)

### About the IEC

The International Electrotechnical Commission (IEC) is the leading global organization that prepares and publishes International Standards for all electrical, electronic and related technologies.

### About IEC publications

The technical content of IEC publications is kept under constant review by the IEC. Please make sure that you have the latest edition, a corrigenda or an amendment might have been published.

#### IEC Catalogue - [webstore.iec.ch/catalogue](http://webstore.iec.ch/catalogue)

The stand-alone application for consulting the entire bibliographical information on IEC International Standards, Technical Specifications, Technical Reports and other documents. Available for PC, Mac OS, Android Tablets and iPad.

#### IEC publications search - [www.iec.ch/searchpub](http://www.iec.ch/searchpub)

The advanced search enables to find IEC publications by a variety of criteria (reference number, text, technical committee,...). It also gives information on projects, replaced and withdrawn publications.

#### IEC Just Published - [webstore.iec.ch/justpublished](http://webstore.iec.ch/justpublished)

Stay up to date on all new IEC publications. Just Published details all new publications released. Available online and also once a month by email.

#### Electropedia - [www.electropedia.org](http://www.electropedia.org)

The world's leading online dictionary of electronic and electrical terms containing 20 000 terms and definitions in English and French, with equivalent terms in 16 additional languages. Also known as the International Electrotechnical Vocabulary (IEV) online.

#### IEC Glossary - [std.iec.ch/glossary](http://std.iec.ch/glossary)

65 000 electrotechnical terminology entries in English and French extracted from the Terms and Definitions clause of IEC publications issued since 2002. Some entries have been collected from earlier publications of IEC TC 37, 77, 86 and CISPR.

#### IEC Customer Service Centre - [webstore.iec.ch/csc](http://webstore.iec.ch/csc)

If you wish to give us your feedback on this publication or need further assistance, please contact the Customer Service Centre: [csc@iec.ch](mailto:csc@iec.ch).



IEC 61076-3-119

Edition 1.0 2017-12

# INTERNATIONAL STANDARD

---

**Connectors for electrical and electronic equipment – Product requirements –  
Part 3-119: Rectangular connectors – Detail specification for shielded and  
unshielded, free and fixed 10-way connectors with push-pull coupling for  
industrial environments for data transmission with frequencies  
up to 100 MHz**

INTERNATIONAL  
ELECTROTECHNICAL  
COMMISSION

---

ICS 31.220.10

ISBN 978-2-8322-5112-6

**Warning! Make sure that you obtained this publication from an authorized distributor.**

## CONTENTS

FOREWORD.....	5
INTRODUCTION.....	7
1 Scope.....	9
2 Normative references .....	9
3 Terms and definitions .....	11
4 Technical information .....	12
4.1 Ratings and characteristics .....	12
4.1.1 Rated current.....	12
4.1.2 Rated voltage .....	12
4.1.3 Insulation resistance.....	12
4.1.4 Voltage proof.....	12
4.2 Performance levels .....	12
4.3 Compatibility levels.....	12
4.4 Climatic categories .....	12
4.5 Clearance and creepage distances .....	12
4.6 Marking.....	13
5 Dimensional information .....	13
5.1 General.....	13
5.2 Isometric view and common features .....	13
5.3 Engagement (mating) information – Contact levels and sequencing .....	13
5.4 Fixed connectors .....	14
5.4.1 Dimensions.....	14
5.4.2 Terminations.....	15
5.5 Free connectors.....	15
5.5.1 Dimensions.....	15
5.5.2 Terminations.....	17
5.5.3 Accessories.....	17
5.6 Mounting information for connectors – Mounting on panels .....	17
5.7 Gauges – Sizing gauges and retention force gauges.....	18
6 Characteristics .....	19
6.1 General.....	19
6.2 Pin assignment and other definitions.....	19
6.3 Classification into climatic categories.....	19
6.4 Electrical characteristics .....	19
6.4.1 Creepage and clearance distances .....	19
6.4.2 Voltage proof.....	19
6.4.3 Current-carrying capacity.....	19
6.4.4 Contact resistance .....	19
6.4.5 Shield to shield resistance .....	19
6.4.6 Insulation resistance.....	20
6.5 Transmission characteristics .....	20
6.5.1 General .....	20
6.5.2 Insertion loss .....	20
6.5.3 Return loss .....	20
6.5.4 NEXT.....	20
6.5.5 FEXT .....	21

6.5.6	Transverse conversion loss .....	21
6.5.7	Transverse conversion transfer loss .....	21
6.5.8	Transfer Impedance.....	21
6.6	Mechanical characteristics .....	21
6.6.1	Mechanical operation.....	21
6.6.2	Effectiveness of connector coupling devices .....	21
6.6.3	Insertion and withdrawal forces .....	21
6.6.4	Contact retention in insert.....	22
6.6.5	Polarizing and coding method.....	22
6.7	Other characteristics .....	22
6.7.1	Vibration (sine) .....	22
6.7.2	Shock .....	22
6.7.3	Degree of protection provided by enclosures (IP-code).....	22
6.7.4	Screen and shielding properties.....	22
6.8	Environmental aspects .....	22
6.8.1	Marking of insulation material (plastics) .....	22
6.8.2	Design/use of material .....	22
7	Test schedule .....	22
7.1	General.....	22
7.1.1	Introductory remarks.....	22
7.1.2	Climatic category .....	23
7.1.3	Clearance and creepage distances .....	23
7.1.4	Arrangement for contact and shield resistance measurement .....	23
7.1.5	Arrangement for dynamic stress tests .....	23
7.1.6	Arrangement for testing static load; axial .....	24
7.1.7	Wiring of specimens .....	24
7.2	Test schedules.....	24
7.2.1	Basic (minimum) test schedule .....	24
7.2.2	Full test schedule .....	24
7.3	Test procedures and measuring methods.....	34
7.4	Pre-conditioning.....	34
7.5	Wiring and mounting of specimens.....	34
7.5.1	Wiring.....	34
7.5.2	Mounting .....	34
	Figure 1 – Fixed (male) and free (female) connector .....	13
	Figure 2 – Fixed connector .....	14
	Figure 3 – Free connector.....	16
	Figure 4 – Panel cut-out.....	18
	Figure 5 – Gauge.....	18
	Figure 6 – Contact / shield resistance arrangement .....	23
	Figure 7 – Connector vibration and shock test arrangement.....	24
	Table 1 – Climatic category.....	12
	Table 2 – Dimensions of the fixed connector.....	15
	Table 3 – Dimensions of the free connector .....	17
	Table 4 – Panel cut-out.....	18

Table 5 – Gauge dimensions.....	19
Table 6 – Number of test specimens and contacts .....	25
Table 7 – Test group P .....	25
Table 8 – Test group AP .....	26
Table 9 – Test group BP .....	28
Table 10 – Test group CP .....	30
Table 11 – Test group DP .....	31
Table 12 – Test group EP .....	32
Table 13 – Test group HP .....	33

## INTERNATIONAL ELECTROTECHNICAL COMMISSION

**CONNECTORS FOR ELECTRICAL AND ELECTRONIC EQUIPMENT –  
PRODUCT REQUIREMENTS –****Part 3-119: Rectangular connectors – Detail specification for shielded and  
unshielded, free and fixed 10-way connectors with push-pull coupling  
for industrial environments for data transmission with frequencies  
up to 100 MHz**

## FOREWORD

- 1) The International Electrotechnical Commission (IEC) is a worldwide organization for standardization comprising all national electrotechnical committees (IEC National Committees). The object of IEC is to promote international co-operation on all questions concerning standardization in the electrical and electronic fields. To this end and in addition to other activities, IEC publishes International Standards, Technical Specifications, Technical Reports, Publicly Available Specifications (PAS) and Guides (hereafter referred to as “IEC Publication(s)”). Their preparation is entrusted to technical committees; any IEC National Committee interested in the subject dealt with may participate in this preparatory work. International, governmental and non-governmental organizations liaising with the IEC also participate in this preparation. IEC collaborates closely with the International Organization for Standardization (ISO) in accordance with conditions determined by agreement between the two organizations.
- 2) The formal decisions or agreements of IEC on technical matters express, as nearly as possible, an international consensus of opinion on the relevant subjects since each technical committee has representation from all interested IEC National Committees.
- 3) IEC Publications have the form of recommendations for international use and are accepted by IEC National Committees in that sense. While all reasonable efforts are made to ensure that the technical content of IEC Publications is accurate, IEC cannot be held responsible for the way in which they are used or for any misinterpretation by any end user.
- 4) In order to promote international uniformity, IEC National Committees undertake to apply IEC Publications transparently to the maximum extent possible in their national and regional publications. Any divergence between any IEC Publication and the corresponding national or regional publication shall be clearly indicated in the latter.
- 5) IEC itself does not provide any attestation of conformity. Independent certification bodies provide conformity assessment services and, in some areas, access to IEC marks of conformity. IEC is not responsible for any services carried out by independent certification bodies.
- 6) All users should ensure that they have the latest edition of this publication.
- 7) No liability shall attach to IEC or its directors, employees, servants or agents including individual experts and members of its technical committees and IEC National Committees for any personal injury, property damage or other damage of any nature whatsoever, whether direct or indirect, or for costs (including legal fees) and expenses arising out of the publication, use of, or reliance upon, this IEC Publication or any other IEC Publications.
- 8) Attention is drawn to the Normative references cited in this publication. Use of the referenced publications is indispensable for the correct application of this publication.
- 9) Attention is drawn to the possibility that some of the elements of this IEC Publication may be the subject of patent rights. IEC shall not be held responsible for identifying any or all such patent rights.

International Standard IEC 61076-3-119 has been prepared by subcommittee 48B: Electrical connectors, of IEC technical committee 48: Electrical connectors and mechanical structures for electrical and electronic equipment.

This first edition cancels and replaces IEC PAS 61076-3-119 published in 2013. This edition constitutes a technical revision.

The text of this International Standard is based on the following documents:

FDIS	Report on voting
48B/2602/FDIS	48B/2617/RVD

Full information on the voting for the approval of this International Standard can be found in the report on voting indicated in the above table.

This document has been drafted in accordance with the ISO/IEC Directives, Part 2.

A list of all parts in the IEC 61076 series, published under the general title *Connectors for electronic equipment – Product requirements*, can be found on the IEC website.

The committee has decided that the contents of this document will remain unchanged until the stability date indicated on the IEC website under "<http://webstore.iec.ch>" in the data related to the specific document. At this date, the document will be

- reconfirmed,
- withdrawn,
- replaced by a revised edition, or
- amended.

A bilingual version of this publication may be issued at a later date.

## INTRODUCTION

The International Electrotechnical Commission (IEC) draws attention to the fact that it is claimed that compliance with this document may involve the use of a patent concerning connectors given in this specification.

The IEC takes no position concerning the evidence, validity and scope of this patent right.

The holder of this patent right has assured the IEC that he is willing to give free licences with applicants throughout the world. In this respect, the statement of the holder of this patent right is registered with the IEC.

Information may be obtained from:

HARTING KGaA  
Marienwerderstrasse 3  
32339 Espelkamp  
Germany

and

Weidmüller Interface GmbH & Co. KG  
Klingenbergstraße 16  
32758 Detmold  
Germany

Attention is drawn to the possibility that some of the elements of this International Standard may be the subject of patent rights other than those identified above. IEC shall not be held responsible for identifying any or all such patent rights.

ISO ([www.iso.org/patents](http://www.iso.org/patents)) and IEC (<http://patents.iec.ch>) maintain on-line data bases of patents relevant to their standards. Users are encouraged to consult the data bases for the most up to date information concerning patents.

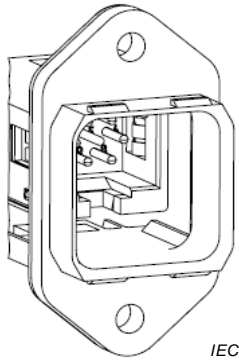
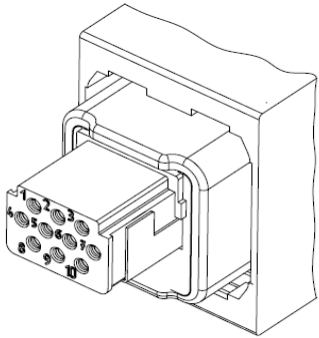
<p>IEC SC 48B – Connector specifications available from: IEC General secretariat or from the addresses shown on the inside cover.</p>		<p>IEC 61076-3-119 Ed. 1.0</p>
<p>ELECTRONIC COMPONENTS DETAIL SPECIFICATION in accordance with IEC 61076-1</p>		
<p>Outline drawing</p>  <p>IEC</p>	 <p>IEC</p>	<p>10-way rectangular connector round contacts Ø 1 mm screw or crimp terminations, solder or printed board connections upon agreement between manufacturer and user shielded and unshielded, free and fixed for data transmission with frequencies up to 100 MHz with push-pull coupling</p>
		<p>Fixed and free connectors, for industrial environments</p>

## CONNECTORS FOR ELECTRICAL AND ELECTRONIC EQUIPMENT – PRODUCT REQUIREMENTS –

### Part 3-119: Rectangular connectors – Detail specification for shielded and unshielded, free and fixed 10-way connectors with push-pull coupling for industrial environments for data transmission with frequencies up to 100 MHz

#### 1 Scope

This part of IEC 61076-3 establishes specifications and test requirements for 10-way shielded and unshielded rectangular, free and fixed connectors, with push-pull coupling, for data transmission with frequencies up to 100 MHz and for use in industrial environments.

This document specifies free and fixed connectors with round contacts, suitable for screw or crimp terminations. Other terminations techniques, such as solder or printed board connections are upon agreement between manufacturer and user. The free and fixed connectors have a push-pull locking mechanism for IP65 and IP67 protection according to IEC 60529.

Connectors according this document are without breaking capacity COC according to 3.9 of IEC 61984:2008, therefore they are not intended to be engaged or disengaged in normal use when live or under load, if not otherwise specified by the manufacturer.

#### 2 Normative references

The following documents are referred to in the text in such a way that some or all of their content constitutes requirements of this document. For dated references, only the edition cited applies. For undated references, the latest edition of the referenced document (including any amendments) applies.

IEC 60050-581:2008, *International Electrotechnical Vocabulary – Part 581: Electromechanical components for electronic equipment*

IEC 60068-1, *Environmental testing – Part 1: General and guidance*

IEC 60068-2-20:2008, *Environmental testing – Part 2-20: Tests – Test T: Test methods for solderability and resistance to soldering heat of devices with leads*

IEC 60352-2, *Solderless connections – Part 2: Crimped connections – General requirements, test methods and practical guidance*

IEC 60352-5, *Solderless connections – Part 5: Press-in connections – General requirements, test methods and practical guidance*

IEC 60512-1-1, *Connectors for electronic equipment – Tests and measurements – Part 1-1: General examination – Test 1a: Visual examination*

IEC 60512-1-2, *Connectors for electronic equipment – Tests and measurements – Part 1-2: General examination – Test 1b: Examination of dimension and mass*