

FINAL VERSION

VERSION FINALE



**Connectors for electronic equipment –
Part 7: Detail specification for 8-way, unshielded, free and fixed connectors**

**Connecteurs pour équipements électroniques –
Partie 7: Spécification particulière pour les fiches et les embases non écrantées
à 8 voies**

CONTENTS

1	General	8
1.1	Scope.....	8
1.2	Normative references	8
2	Terms and definitions	10
3	Common features and typical connector pair	12
3.1	View showing typical fixed and free connectors	12
3.2	Mating information.....	12
3.2.1	General	12
3.2.2	Contacts – mating conditions.....	13
3.2.3	Fixed connector.....	15
3.2.4	Free connector	18
4	Cable terminations and internal connections – Fixed and free connectors	20
4.1	General.....	20
4.2	Termination types.....	20
4.2.1	Solder terminations (under consideration)	20
4.2.2	Solderless terminations	20
5	Gauges	21
5.1	Fixed connectors.....	21
5.2	Free connectors	24
6	Characteristics	26
6.1	General.....	26
6.2	Pin and pair grouping assignment	26
6.3	Classification into climatic category.....	26
6.4	Electrical characteristics.....	27
6.4.1	Creepage and clearance distances	27
6.4.2	Voltage proof.....	27
6.4.3	Current-temperature derating	27
6.4.4	Initial contact resistance – interface only (separable fixed and free contact)	28
6.4.5	Input to output d.c. resistance	28
6.4.6	Input-to-output d.c. resistance unbalance	28
6.4.7	Initial insulation resistance	29
6.4.8	Transfer impedance.....	29
6.5	Transmission characteristics	29
6.6	Mechanical characteristics	29
6.6.1	Mechanical operation	29
6.6.2	Effectiveness of connector coupling devices	29
6.6.3	Insertion and withdrawal forces	29
7	Tests and test schedule.....	29
7.1	General.....	29
7.2	Arrangement for contact resistance test	30
7.3	Arrangement for vibration test (test phase CP1)	31
7.4	Test procedures and measuring methods	31
7.5	Preconditioning	32
7.6	Wiring and mounting of specimens	32
7.6.1	Wiring.....	32

7.6.2	Mounting	32
7.7	Test schedules	32
7.7.1	Basic (minimum) test schedule	32
7.7.2	Full test schedule	32
Annex A (normative)	Gauging continuity procedure.....	41
Annex B (normative)	Locking-device mechanical operation.....	45
Annex C (normative)	Gauge requirements	46
Annex D (normative)	Keystone connector information	47
Annex E (normative)	Levels of compatibility.....	49
Figure 1 –	View showing typical fixed and free connectors.....	12
Figure 2 –	Contact interface dimensions with terminated free connector	13
Figure 3 –	Fixed connector details	16
Figure 4 –	Free connector view.....	18
Figure 5 –	“Go” gauge.....	21
Figure 6 –	“No-go” gauges	23
Figure 7 –	“No-go” gauges	24
Figure 8 –	“Go” gauge.....	25
Figure 9 –	Fixed connector pin and pair grouping assignment (front view of connector)	26
Figure 10 –	Connector de-rating curve	28
Figure 11 –	Arrangement for contact resistance test	30
Figure 12 –	Arrangement for vibration test	31
Figure A.1 –	Gauge.....	43
Figure A.2 –	Gauge insertion	44
Figure D.1 –	Keystone connector	47
Figure D.2 –	Panel drawing.....	48
Table 1 –	Dimensions for Figure 2	14
Table 2 –	Dimensions for Figure 3	17
Table 3 –	Dimensions for Figure 4	19
Table 4 –	Dimensions for Figures 5 and 6.....	23
Table 5 –	Dimensions for Figure 7	24
Table 6 –	Dimensions for Figure 8	25
Table 7 –	Climatic categories – selected values.....	26
Table 8 –	Creepage and clearance distances.....	27
Table 9 –	Test group P	33
Table 10 –	Test group AP	34
Table 11 –	Test group BP	36
Table 12 –	Test group CP	37
Table 13 –	Test group DP	38
Table 14 –	Test group EP	39
Table 15 –	Test group FP	40
Table A.1 –	Dimensions for Figure A.1	42
Table D.1 –	Dimensions for Figure D.1	47

Table D.2 – Dimensions.....	48
Table E.1 – Levels of compatibility ^{b)} ^{c)} and required parameters ^{b)}	50

INTERNATIONAL ELECTROTECHNICAL COMMISSION

CONNECTORS FOR ELECTRONIC EQUIPMENT –

Part 7: Detail specification for 8-way, unshielded, free and fixed connectors

FOREWORD

- 1) The International Electrotechnical Commission (IEC) is a worldwide organization for standardization comprising all national electrotechnical committees (IEC National Committees). The object of IEC is to promote international co-operation on all questions concerning standardization in the electrical and electronic fields. To this end and in addition to other activities, IEC publishes International Standards, Technical Specifications, Technical Reports, Publicly Available Specifications (PAS) and Guides (hereafter referred to as “IEC Publication(s)”). Their preparation is entrusted to technical committees; any IEC National Committee interested in the subject dealt with may participate in this preparatory work. International, governmental and non-governmental organizations liaising with the IEC also participate in this preparation. IEC collaborates closely with the International Organization for Standardization (ISO) in accordance with conditions determined by agreement between the two organizations.
- 2) The formal decisions or agreements of IEC on technical matters express, as nearly as possible, an international consensus of opinion on the relevant subjects since each technical committee has representation from all interested IEC National Committees.
- 3) IEC Publications have the form of recommendations for international use and are accepted by IEC National Committees in that sense. While all reasonable efforts are made to ensure that the technical content of IEC Publications is accurate, IEC cannot be held responsible for the way in which they are used or for any misinterpretation by any end user.
- 4) In order to promote international uniformity, IEC National Committees undertake to apply IEC Publications transparently to the maximum extent possible in their national and regional publications. Any divergence between any IEC Publication and the corresponding national or regional publication shall be clearly indicated in the latter.
- 5) IEC itself does not provide any attestation of conformity. Independent certification bodies provide conformity assessment services and, in some areas, access to IEC marks of conformity. IEC is not responsible for any services carried out by independent certification bodies.
- 6) All users should ensure that they have the latest edition of this publication.
- 7) No liability shall attach to IEC or its directors, employees, servants or agents including individual experts and members of its technical committees and IEC National Committees for any personal injury, property damage or other damage of any nature whatsoever, whether direct or indirect, or for costs (including legal fees) and expenses arising out of the publication, use of, or reliance upon, this IEC Publication or any other IEC Publications.
- 8) Attention is drawn to the Normative references cited in this publication. Use of the referenced publications is indispensable for the correct application of this publication.
- 9) Attention is drawn to the possibility that some of the elements of this IEC Publication may be the subject of patent rights. IEC shall not be held responsible for identifying any or all such patent rights.

DISCLAIMER

This Consolidated version is not an official IEC Standard and has been prepared for user convenience. Only the current versions of the standard and its amendment(s) are to be considered the official documents.

This Consolidated version of IEC 60603-7 bears the edition number 3.2. It consists of the first edition (2008-07) [documents 48B/1883A/FDIS and 48B/1917/RVD], its amendment 1 (2011-09) [documents 48B/2145/CDV and 48B/2205/RVC] and its amendment 2 (2019-01) [documents 48B/2679/FDIS and 48B/2689/RVD]. The technical content is identical to the base edition and its amendments.

This Final version does not show where the technical content is modified by amendments 1 and 2. A separate Redline version with all changes highlighted is available in this publication.

International Standard IEC 60603-7 has been prepared by subcommittee 48B: Connectors, of IEC technical committee 48: Electromechanical components and mechanical structures for electronic equipment.

This third edition cancels and replaces the second edition published in 1996 and constitutes a technical revision. This edition includes the following significant technical change with respect to the previous edition:

- Drawings and test schedules were updated based on the work done developing IEC 60603-7-4.
- A corrected figure (Figure 10) illustrating a connector de-rating curve has been prepared and inserted in the text.
- Annex D contains the dimensions that define the panel mounting features on the connector and panel that were referenced as the Type A, variant 03 connector in the previous edition.

This publication has been drafted in accordance with the ISO/IEC Directives, Part 2.

A list of all parts of IEC 60603-7 series, under the general title: *Connectors for electronic equipment*, can be found on the IEC website.

The committee has decided that the contents of the base publication and its amendments will remain unchanged until the stability date indicated on the IEC web site under "<http://webstore.iec.ch>" in the data related to the specific publication. At this date, the publication will be

- reconfirmed,
- withdrawn,
- replaced by a revised edition, or
- amended.

IMPORTANT – The “colour inside” logo on the cover page of this publication indicates that it contains colours which are considered to be useful for the correct understanding of its contents. Users should therefore print this publication using a colour printer.

INTRODUCTION

IEC 60603-7 is the base specification of the whole series. Subsequent specifications do not duplicate information given in the base document, but list only additional requirements. For complete specification regarding a component of a higher number document all lower numbered documents must be considered as well. The following diagram shows the interrelation of the documents:

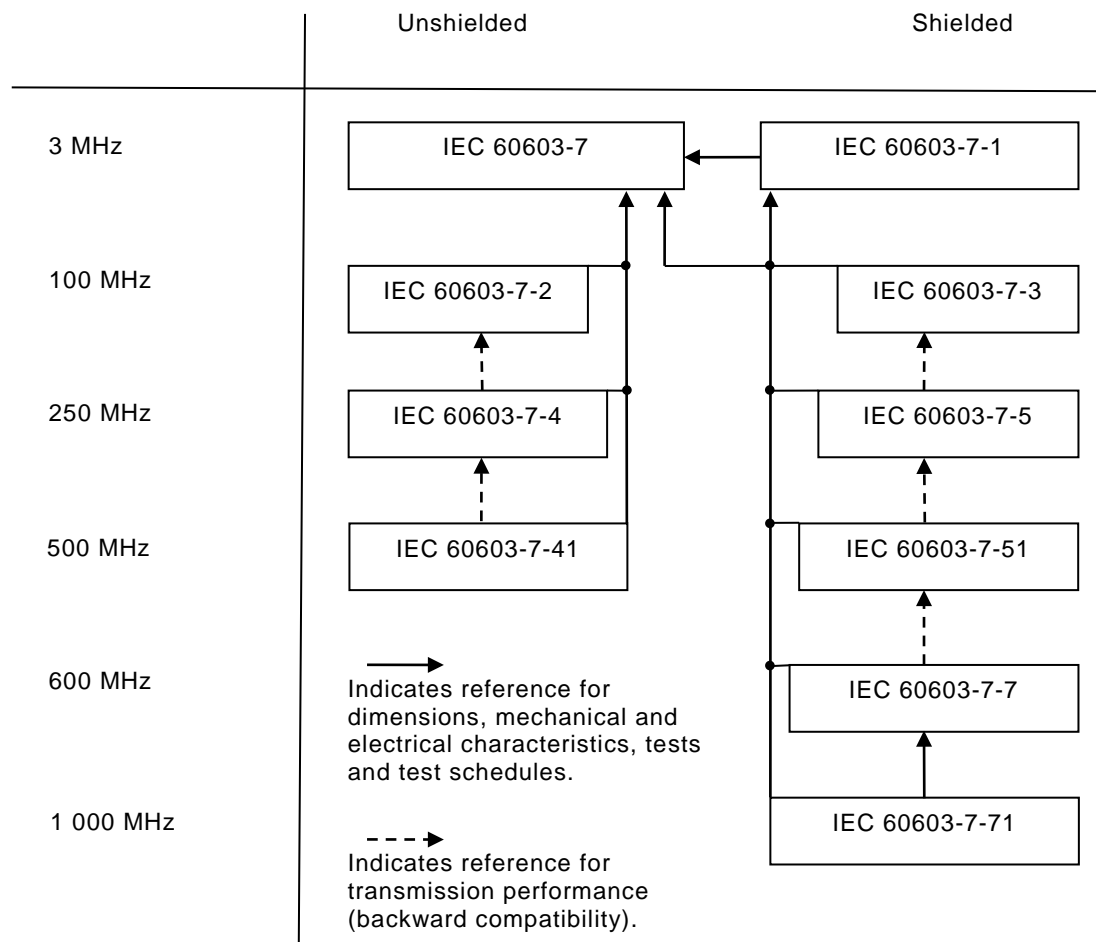

It should be noted that during the preparation of the third edition of IEC 60603-7, the subcommittee 48B Cat 6&7 project team members determined the current de-rating curve in the standard was not correct. Several experts researched the current rating-temperature rise measurements for 60603-7 style connectors and verified that the de-rating curve in the published standard has been incorrect for many years. A corrected figure (Figure 10) has been prepared and inserted in this edition.

CONNECTORS FOR ELECTRONIC EQUIPMENT –

Part 7: Detail specification for 8-way, unshielded, free and fixed connectors

1 General

1.1 Scope

This part of IEC 60603-7 covers 8-way unshielded free and fixed connectors, it is intended to specify the common dimensions, mechanical, electrical and environmental characteristics and tests for the family of IEC 60603-7-x connectors.

These connectors are intermateable (according to IEC 61076-1 level 2) and interoperable with other IEC 60603-7 series connectors.

Annex E (normative) is added to provide details regarding the levels of compatibility to be declared by the manufacturer as appropriate.

1.2 Normative references

The following referenced documents are indispensable for the application of this document. For dated references, only the edition cited applies. For undated references, the latest edition of the referenced document (including any amendments) applies.

IEC 60050-581, *International Electrotechnical Vocabulary (IEV) – Chapter 581: Electromechanical components for electronic equipment*

IEC 60068-1, *Environmental testing – Part 1: General and guidance*

IEC 60068-2-14, *Basic environmental testing procedures – Part 2-14: Tests – Test N: Change of temperature*

IEC 60068-2-38, *Basic environmental testing procedures – Part 2-38: Tests – Test Z/AD: Composite temperature/ humidity cyclic test*

IEC 60352-2, *Solderless connections – Part 2: Crimped connections – General requirements, test methods and practical guidance*

IEC 60352-3, *Solderless connections – Part 3: Solderless accessible insulation displacement connections – General requirements, test methods and practical guidance*

IEC 60352-4, *Solderless connections – Part 4: Solderless non-accessible insulation displacement connections – General requirements, test methods and practical guidance*

IEC 60352-5, *Solderless connections – Part 5: Press-in connections – General requirements, test methods and practical guidance*

IEC 60352-6, *Solderless connections – Part 6: Insulation piercing connections – General requirements, test methods and practical guidance*

IEC 60352-7, *Solderless connections – Part 7: Spring clamp connections – General requirements, test methods and practical guidance*