

DETAIL SPECIFICATION SHEET

SWITCH, ROTARY, CLOSED CONSTRUCTION, EXPLOSION PROOF,
FLUX SEAL AND NON-FLUX SEAL, .200 AMPERE, STYLE SR35

This specification is approved for use by all Departments and Agencies of the Department of Defense.

The complete requirements for acquiring the switches described herein shall consist of this specification and the latest issue of MIL-DTL-3786.

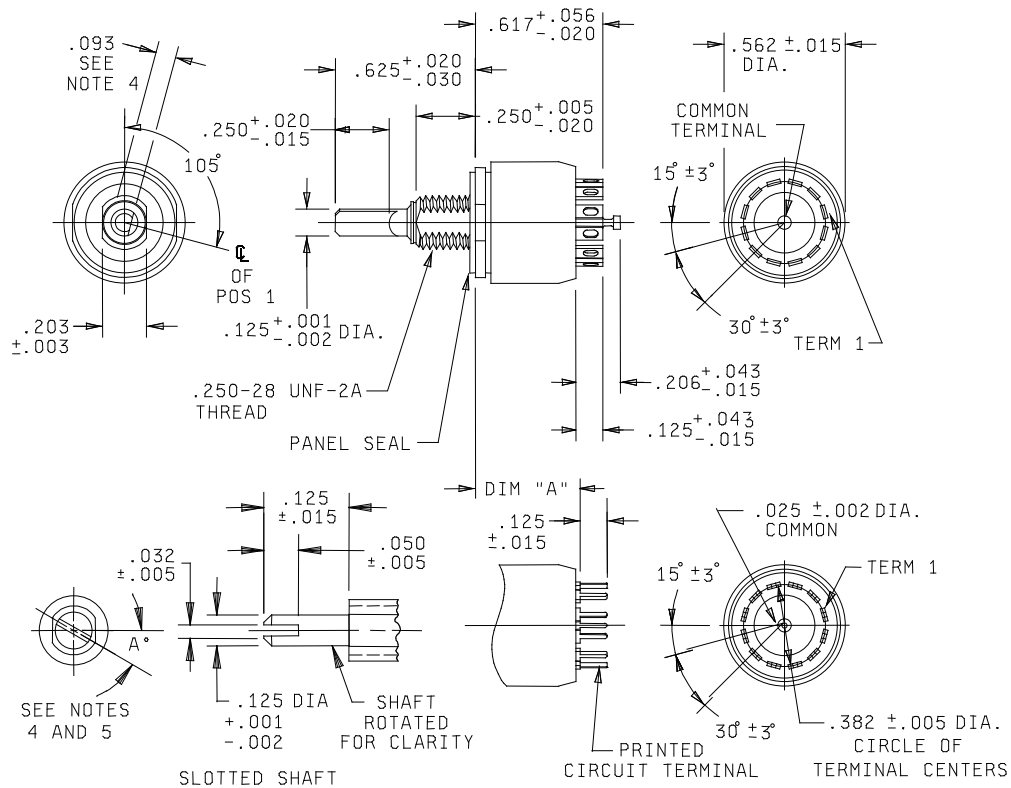

COMMON LOCATION FOR SINGLE POLE SWITCH. SEE DETAIL FOR LOCATION OF COMMONS ON MULTIPOLE SWITCHES.

FIGURE 1. Switch style SR35.

