

INTERNATIONAL STANDARD

**Flow battery energy systems for stationary applications –
Part 2-1: Performance general requirements and test methods**





THIS PUBLICATION IS COPYRIGHT PROTECTED

Copyright © 2020 IEC, Geneva, Switzerland

All rights reserved. Unless otherwise specified, no part of this publication may be reproduced or utilized in any form or by any means, electronic or mechanical, including photocopying and microfilm, without permission in writing from either IEC or IEC's member National Committee in the country of the requester. If you have any questions about IEC copyright or have an enquiry about obtaining additional rights to this publication, please contact the address below or your local IEC member National Committee for further information.

IEC Central Office
3, rue de Varembe
CH-1211 Geneva 20
Switzerland

Tel.: +41 22 919 02 11
info@iec.ch
www.iec.ch

About the IEC

The International Electrotechnical Commission (IEC) is the leading global organization that prepares and publishes International Standards for all electrical, electronic and related technologies.

About IEC publications

The technical content of IEC publications is kept under constant review by the IEC. Please make sure that you have the latest edition, a corrigendum or an amendment might have been published.

IEC publications search - webstore.iec.ch/advsearchform

The advanced search enables to find IEC publications by a variety of criteria (reference number, text, technical committee,...). It also gives information on projects, replaced and withdrawn publications.

IEC Just Published - webstore.iec.ch/justpublished

Stay up to date on all new IEC publications. Just Published details all new publications released. Available online and once a month by email.

IEC Customer Service Centre - webstore.iec.ch/csc

If you wish to give us your feedback on this publication or need further assistance, please contact the Customer Service Centre: sales@iec.ch.

Electropedia - www.electropedia.org

The world's leading online dictionary on electrotechnology, containing more than 22 000 terminological entries in English and French, with equivalent terms in 16 additional languages. Also known as the International Electrotechnical Vocabulary (IEV) online.

IEC Glossary - std.iec.ch/glossary

67 000 electrotechnical terminology entries in English and French extracted from the Terms and Definitions clause of IEC publications issued since 2002. Some entries have been collected from earlier publications of IEC TC 37, 77, 86 and CISPR.



IEC 62932-2-1

Edition 1.0 2020-02

INTERNATIONAL STANDARD

**Flow battery energy systems for stationary applications –
Part 2-1: Performance general requirements and test methods**

INTERNATIONAL
ELECTROTECHNICAL
COMMISSION

ICS 29.220.99

ISBN 978-2-8322-7853-6

Warning! Make sure that you obtained this publication from an authorized distributor.

CONTENTS

FOREWORD.....	3
INTRODUCTION.....	5
1 Scope.....	6
2 Normative references	6
3 Terms, definitions and abbreviated terms	6
3.1 Terms and definitions.....	6
3.2 Abbreviated terms.....	6
4 General requirements	7
5 General test conditions.....	7
5.1 Accuracy of measuring instruments.....	7
5.1.1 Voltage measurement.....	7
5.1.2 Current measurement.....	7
5.1.3 Electric energy measurement	7
5.1.4 Temperature measurement.....	7
5.1.5 Time measurement.....	7
5.2 Ambient temperature.....	7
5.3 Point of connection (POC) and point of measurement (POM).....	8
5.4 Test object.....	9
5.5 Test object unit (TOU) selection.....	9
6 Test methods.....	9
6.1 Determination of energy at a constant power	9
6.1.1 General	9
6.1.2 Test procedures.....	9
6.2 Determination of maximum deliverable output power	10
6.2.1 General	10
6.2.2 Test procedures.....	10
6.3 Determination of maximum receivable input power.....	11
6.3.1 General	11
6.3.2 Test procedures.....	11
6.4 Determination of energy efficiency at a constant power level	12
6.4.1 General	12
6.4.2 Test procedures.....	12
6.5 Determination of cycle life.....	13
Annex A (informative) Testing of discharge power vs energy or energy efficiency	14
Figure 1 – Flow battery energy system.....	5
Figure 2 – POM/POC interconnection cases a), b), c).....	8

INTERNATIONAL ELECTROTECHNICAL COMMISSION

FLOW BATTERY ENERGY SYSTEMS FOR STATIONARY APPLICATIONS –**Part 2-1: Performance general requirements and test methods**

FOREWORD

- 1) The International Electrotechnical Commission (IEC) is a worldwide organization for standardization comprising all national electrotechnical committees (IEC National Committees). The object of IEC is to promote international co-operation on all questions concerning standardization in the electrical and electronic fields. To this end and in addition to other activities, IEC publishes International Standards, Technical Specifications, Technical Reports, Publicly Available Specifications (PAS) and Guides (hereafter referred to as "IEC Publication(s)"). Their preparation is entrusted to technical committees; any IEC National Committee interested in the subject dealt with may participate in this preparatory work. International, governmental and non-governmental organizations liaising with the IEC also participate in this preparation. IEC collaborates closely with the International Organization for Standardization (ISO) in accordance with conditions determined by agreement between the two organizations.
- 2) The formal decisions or agreements of IEC on technical matters express, as nearly as possible, an international consensus of opinion on the relevant subjects since each technical committee has representation from all interested IEC National Committees.
- 3) IEC Publications have the form of recommendations for international use and are accepted by IEC National Committees in that sense. While all reasonable efforts are made to ensure that the technical content of IEC Publications is accurate, IEC cannot be held responsible for the way in which they are used or for any misinterpretation by any end user.
- 4) In order to promote international uniformity, IEC National Committees undertake to apply IEC Publications transparently to the maximum extent possible in their national and regional publications. Any divergence between any IEC Publication and the corresponding national or regional publication shall be clearly indicated in the latter.
- 5) IEC itself does not provide any attestation of conformity. Independent certification bodies provide conformity assessment services and, in some areas, access to IEC marks of conformity. IEC is not responsible for any services carried out by independent certification bodies.
- 6) All users should ensure that they have the latest edition of this publication.
- 7) No liability shall attach to IEC or its directors, employees, servants or agents including individual experts and members of its technical committees and IEC National Committees for any personal injury, property damage or other damage of any nature whatsoever, whether direct or indirect, or for costs (including legal fees) and expenses arising out of the publication, use of, or reliance upon, this IEC Publication or any other IEC Publications.
- 8) Attention is drawn to the Normative references cited in this publication. Use of the referenced publications is indispensable for the correct application of this publication.
- 9) Attention is drawn to the possibility that some of the elements of this IEC Publication may be the subject of patent rights. IEC shall not be held responsible for identifying any or all such patent rights.

International Standard IEC 62932-2-1 has been prepared by IEC technical committee 21: Secondary cells and batteries, in collaboration with IEC technical committee 105: Fuel cell technologies.

The text of this International Standard is based on the following documents:

FDIS	Report on voting
21/1028/FDIS	21/1036/RVD

Full information on the voting for the approval of this International Standard can be found in the report on voting indicated in the above table.

This document has been drafted in accordance with the ISO/IEC Directives, Part 2.

A list of all parts in the IEC 62932 series, published under the general title *Flow battery energy systems for stationary applications*, can be found on the IEC website.

The committee has decided that the contents of this document will remain unchanged until the stability date indicated on the IEC website under "<http://webstore.iec.ch>" in the data related to the specific document. At this date, the document will be

- reconfirmed,
- withdrawn,
- replaced by a revised edition, or
- amended.

INTRODUCTION

A flow battery system (FBS) can be utilized as a main part of a flow battery energy system (FBES). Such an FBES can consist of:

- a flow battery system,
- a power conversion system,
- other equipment and surroundings.

The FBES is connected to the external power input or output via a point of connection (POC).

This document includes the domain of the FBES, as shown in Figure 1. Auxiliary energy to the battery management system (BMS), battery support system (BSS), and power conversion system (PCS) may be supplied by one of the following:

- direct connection to the external power source;
- the internal power source of the FBES or FBS itself.

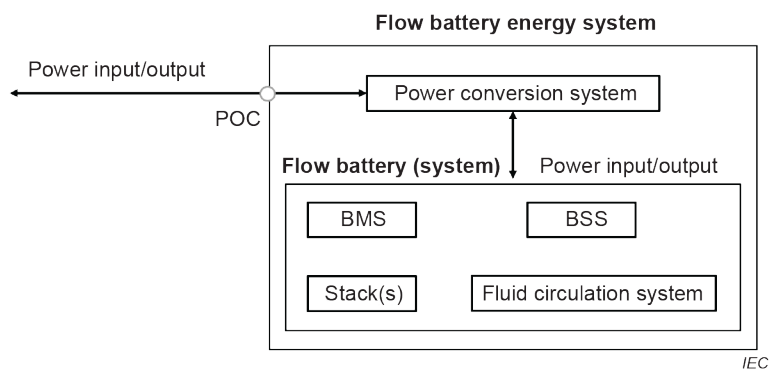

Figure 1 – Flow battery energy system

FLOW BATTERY ENERGY SYSTEMS FOR STATIONARY APPLICATIONS –

Part 2-1: Performance general requirements and test methods

1 Scope

This part of IEC 62932 specifies methods of test and requirements for the flow battery system (FBS) and the flow battery energy system (FBES) for the verification of their performances.

This document is applicable to FBES or FBS which are designed and used for service in stationary locations (i.e. not generally to be moved from place to place).

This document does not cover testing of the system for electromagnetic compatibility (EMC).

2 Normative references

The following documents are referred to in the text in such a way that some or all of their content constitutes requirements of this document. For dated references, only the edition cited applies. For undated references, the latest edition of the referenced document (including any amendments) applies.

IEC 62932-1, *Flow battery energy systems for stationary applications – Part 1: Terminology and general aspects*

IEC 62932-2-2, *Flow battery energy systems for stationary applications – Part 2-2: Safety requirements*

IEC 61427-2, *Secondary cells and batteries for renewable energy storage – General requirements and methods of test – Part 2: On-grid applications*

3 Terms, definitions and abbreviated terms

3.1 Terms and definitions

For the purposes of this document the terms and definitions given in IEC 62932-1 apply.

ISO and IEC maintain terminological databases for use in standardization at the following addresses:

- IEC Electropedia: available at <http://www.electropedia.org/>.
- ISO Online browsing platform: available at <http://www.iso.org/obp>.

3.2 Abbreviated terms

BMS	battery management system
BSS	battery support system
FBES	flow battery energy system
FBS	flow battery system
PCS	power conversion system
POC	point of connection
POM	point of measurement
TOU	test object unit