

INTERNATIONAL STANDARD

NORME INTERNATIONALE



**Engineering data exchange format for use in industrial automation systems
engineering – Automation markup language –
Part 4: Logic**

**Format d'échange de données pour une utilisation dans l'ingénierie des
systèmes d'automatisation industrielle – Automation markup language –
Partie 4: Logique**



THIS PUBLICATION IS COPYRIGHT PROTECTED
Copyright © 2020 IEC, Geneva, Switzerland

All rights reserved. Unless otherwise specified, no part of this publication may be reproduced or utilized in any form or by any means, electronic or mechanical, including photocopying and microfilm, without permission in writing from either IEC or IEC's member National Committee in the country of the requester. If you have any questions about IEC copyright or have an enquiry about obtaining additional rights to this publication, please contact the address below or your local IEC member National Committee for further information.

Droits de reproduction réservés. Sauf indication contraire, aucune partie de cette publication ne peut être reproduite ni utilisée sous quelque forme que ce soit et par aucun procédé, électronique ou mécanique, y compris la photocopie et les microfilms, sans l'accord écrit de l'IEC ou du Comité national de l'IEC du pays du demandeur. Si vous avez des questions sur le copyright de l'IEC ou si vous désirez obtenir des droits supplémentaires sur cette publication, utilisez les coordonnées ci-après ou contactez le Comité national de l'IEC de votre pays de résidence.

IEC Central Office
3, rue de Varembe
CH-1211 Geneva 20
Switzerland

Tel.: +41 22 919 02 11
info@iec.ch
www.iec.ch

About the IEC

The International Electrotechnical Commission (IEC) is the leading global organization that prepares and publishes International Standards for all electrical, electronic and related technologies.

About IEC publications

The technical content of IEC publications is kept under constant review by the IEC. Please make sure that you have the latest edition, a corrigendum or an amendment might have been published.

IEC publications search - webstore.iec.ch/advsearchform

The advanced search enables to find IEC publications by a variety of criteria (reference number, text, technical committee,...). It also gives information on projects, replaced and withdrawn publications.

IEC Just Published - webstore.iec.ch/justpublished

Stay up to date on all new IEC publications. Just Published details all new publications released. Available online and once a month by email.

IEC Customer Service Centre - webstore.iec.ch/csc

If you wish to give us your feedback on this publication or need further assistance, please contact the Customer Service Centre: sales@iec.ch.

Electropedia - www.electropedia.org

The world's leading online dictionary on electrotechnology, containing more than 22 000 terminological entries in English and French, with equivalent terms in 16 additional languages. Also known as the International Electrotechnical Vocabulary (IEV) online.

IEC Glossary - std.iec.ch/glossary

67 000 electrotechnical terminology entries in English and French extracted from the Terms and Definitions clause of IEC publications issued since 2002. Some entries have been collected from earlier publications of IEC TC 37, 77, 86 and CISPR.

A propos de l'IEC

La Commission Electrotechnique Internationale (IEC) est la première organisation mondiale qui élabore et publie des Normes internationales pour tout ce qui a trait à l'électricité, à l'électronique et aux technologies apparentées.

A propos des publications IEC

Le contenu technique des publications IEC est constamment revu. Veuillez vous assurer que vous possédez l'édition la plus récente, un corrigendum ou amendement peut avoir été publié.

Recherche de publications IEC - webstore.iec.ch/advsearchform

La recherche avancée permet de trouver des publications IEC en utilisant différents critères (numéro de référence, texte, comité d'études,...). Elle donne aussi des informations sur les projets et les publications remplacées ou retirées.

IEC Just Published - webstore.iec.ch/justpublished

Restez informé sur les nouvelles publications IEC. Just Published détaille les nouvelles publications parues. Disponible en ligne et une fois par mois par email.

Service Clients - webstore.iec.ch/csc

Si vous désirez nous donner des commentaires sur cette publication ou si vous avez des questions contactez-nous: sales@iec.ch.

Electropedia - www.electropedia.org

Le premier dictionnaire d'électrotechnologie en ligne au monde, avec plus de 22 000 articles terminologiques en anglais et en français, ainsi que les termes équivalents dans 16 langues additionnelles. Egalement appelé Vocabulaire Electrotechnique International (IEV) en ligne.

Glossaire IEC - std.iec.ch/glossary

67 000 entrées terminologiques électrotechniques, en anglais et en français, extraites des articles Termes et Définitions des publications IEC parues depuis 2002. Plus certaines entrées antérieures extraites des publications des CE 37, 77, 86 et CISPR de l'IEC.

INTERNATIONAL STANDARD

NORME INTERNATIONALE



**Engineering data exchange format for use in industrial automation systems
engineering – Automation markup language –
Part 4: Logic**

**Format d'échange de données pour une utilisation dans l'ingénierie des
systèmes d'automatisation industrielle – Automation markup language –
Partie 4: Logique**

INTERNATIONAL
ELECTROTECHNICAL
COMMISSION

COMMISSION
ELECTROTECHNIQUE
INTERNATIONALE

ICS 25.040.40

ISBN 978-2-8322-8399-8

**Warning! Make sure that you obtained this publication from an authorized distributor.
Attention! Veuillez vous assurer que vous avez obtenu cette publication via un distributeur agréé.**

CONTENTS

FOREWORD.....	9
INTRODUCTION.....	11
1 Scope.....	13
2 Normative references	13
3 Terms, definitions and abbreviated terms	14
3.1 Terms and definitions.....	14
3.2 Abbreviated terms.....	15
4 Conformity.....	16
5 Overview	16
5.1 Logic information in production system engineering	16
5.2 Logic models in production system engineering	17
5.3 Storing logic models in AML logic XML	18
5.4 Referencing logic information.....	20
6 Logic models	21
6.1 General.....	21
6.2 Gantt charts	21
6.2.1 General	21
6.2.2 Graphical elements.....	21
6.2.3 Chart structure.....	21
6.2.4 Logic information	22
6.2.5 Logic information within Gantt chart.....	22
6.3 Activity-on-node networks	22
6.3.1 General	22
6.3.2 Graphical elements.....	22
6.3.3 Node structure.....	23
6.3.4 Network structure	23
6.3.5 Logic information	23
6.3.6 Logic information within activity-on-node networks.....	23
6.4 Timing diagrams	24
6.4.1 General	24
6.4.2 Graphical elements.....	24
6.4.3 Diagram structure	25
6.4.4 Logic information	25
6.4.5 Logic information within timing diagrams	26
6.5 Sequential function charts.....	26
6.6 Function block diagrams	27
6.7 Mathematical expression.....	27
7 AML logic XML schema description	27
7.1 Schema overview.....	27
7.1.1 Use of IEC 61131-10 schema	27
7.1.2 Schema versioning	28
7.2 Root element "AMLLogic"	29
7.2.1 General	29
7.2.2 Attributes.....	29
7.2.3 Sub-element "WriterHeader"	29
7.2.4 Sub-element "Types"	29

7.2.5	Sub-element "Documentation"	30
7.3	Complex type "FunctionBlock"	30
7.3.1	General	30
7.3.2	Attributes	30
7.3.3	Sub-element "Parameters"	30
7.3.4	Sub-element "Vars"	30
7.3.5	Sub-element "MainBody"	30
7.3.6	Complex type "ParameterSet"	31
7.3.7	Complex type "VariableDecl"	31
7.4	Complex Type "IML"	32
7.4.1	General	32
7.4.2	Attributes	33
7.4.3	Sub-element "Resource"	33
7.4.4	Sub-element "TimeInformation"	33
7.4.5	Choice of "IML****" element	33
7.4.6	Complex type "IMLStep"	33
7.4.7	Complex type "IMLTransition"	34
7.4.8	Complex type "IMLSimultaneousDivergence"	35
7.4.9	Complex type "IMLSimultaneousConvergence"	35
7.5	Complex Type "MathematicalExpression"	35
7.5.1	General	35
7.5.2	Attributes	36
7.5.3	Sub-element "VariableMapping"	36
7.5.4	Sub-element "MathML"	36
7.6	Simple type "LogicModelTypeEnum"	36
7.7	Simple type "TimeUnion"	36
7.8	Simple type "TimeFormatEnum"	36
7.9	Simple type "UuidString"	37
8	Storing logic models	37
8.1	General	37
8.2	Storing Gantt charts in AML logic XML	37
8.2.1	Common rules	37
8.2.2	Storing the start of a Gantt chart	37
8.2.3	Storing bars	38
8.2.4	Storing arrows	38
8.2.5	Storing successor bars	39
8.2.6	Storing predecessor bars	41
8.3	Storing activity-on-node networks in AML logic XML	42
8.3.1	Common rules	42
8.3.2	Storing the start of an activity-on-node network	42
8.3.3	Storing nodes	43
8.3.4	Storing arrows	43
8.3.5	Storing successor nodes	44
8.3.6	Storing predecessor nodes	45
8.4	Storing timing diagrams in AML logic XML	46
8.4.1	Common rules	46
8.4.2	Storing the timeline of a timing diagram	47
8.4.3	Storing resources and resource states	48
8.4.4	Storing lifelines	48

8.4.5	Storing the time signal and the resource signal.....	50
8.5	Storing sequential function charts in AML logic XML	52
8.5.1	Common rules	52
8.5.2	Storing variables.....	52
8.6	Storing function block diagrams in AML logic XML	53
8.6.1	Common rules	53
8.6.2	Storing variables.....	53
8.7	Storing mathematical expressions in AML logic XML.....	54
8.7.1	Common rules	54
8.7.2	Storing variables.....	55
8.7.3	Storing variable mappings	55
8.7.4	Storing mathematical expressions	56
9	Meta information about AML logic XML writer tools.....	56
10	Extensions of AML classes for logic.....	57
10.1	General.....	57
10.2	AutomationMLLogicRoleClassLib	57
10.2.1	General	57
10.2.2	RoleClass InterlockingTargetGroup	58
10.2.3	RoleClass InterlockingSourceGroup	58
10.2.4	RoleClass LogicModelObject	59
10.3	AutomationMLLogicInterfaceClassLib	60
10.3.1	General	60
10.3.2	InterfaceClass LogicModelInterface	60
10.3.3	InterfaceClass SequencingLogicModelInterface	60
10.3.4	InterfaceClass BehaviourLogicModelInterface	61
10.3.5	InterfaceClass InterlockingLogicModelInterface	61
10.3.6	InterfaceClass LogicModelElementInterface	61
10.3.7	InterfaceClass VariableInterface	62
10.3.8	InterfaceClass InterlockingVariableInterface	62
10.4	AutomationMLPLCopenXMLInterfaceClassLib.....	63
10.4.1	General	63
10.4.2	InterfaceClass VariableInterface	63
10.5	AutomationMLInterfaceClassLib.....	64
10.5.1	General	64
10.5.2	InterfaceClass InterlockingConnector	64
10.5.3	InterfaceClass PLCopenXMLInterface	64
11	Referencing AML logic XML documents.....	64
11.1	General.....	64
11.2	Referencing logic information.....	64
12	Linking AML objects with interlocking information	65
12.1	General.....	65
12.2	Referencing interlocking information	65
Annex A (informative)	Examples for storing logic models in AML logic XML	67
A.1	Example for storing Gantt charts	67
A.1.1	General	67
A.1.2	Storing of activities without predecessor and successor relation	67
A.1.3	Storing of an activity sequence	68
A.1.4	Storing of an activity sequence with divergences	70

A.1.5	Storing of an activity sequence with convergences	71
A.2	Example for storing activity-on-node networks	72
A.2.1	General	72
A.2.2	Storing of activities without predecessor and successor relation	72
A.2.3	Storing of an activity sequence	73
A.2.4	Storing of an activity sequence with divergences	74
A.2.5	Storing of an activity sequence with convergences	75
A.3	Example for storing timing diagrams	76
A.3.1	General	76
A.3.2	Example of storing internal signal	77
A.3.3	Example of storing external signal	78
A.3.4	Example of storing signal between two resource states flows	79
A.4	Example for storing sequential function charts	81
A.5	Example for storing function block diagrams	83
A.6	Example for storing mathematical expressions.....	85
Annex B (informative)	Examples for referencing logic information	89
B.1	General.....	89
B.2	Referencing logic information expressed as logic models.....	89
B.2.1	General	89
B.2.2	Referencing logic information stored in one FunctionBlock	89
B.2.3	Referencing logic information, which is composed of several FunctionBlocks	90
B.2.4	Referencing logic information, which is composed of several AML logic XML documents.....	90
B.3	Referencing logic information as a part of logic models.....	92
B.3.1	General	92
B.3.2	Referencing a variable.....	92
B.3.3	Referencing a logic element	93
B.4	Referencing logic information as a part of already referenced logic models.....	93
Annex C (informative)	Examples for referencing interlocking information	96
C.1	General.....	96
C.2	Interlocking information.....	97
C.3	Referencing interlocking information without interlocking condition	97
C.4	Referencing interlocking information with interlocking condition	99
Annex D (normative)	XML representation of AML standard libraries.....	103
D.1	General.....	103
D.2	AutomationMLLogicRoleClassLib	103
D.3	AutomationMLLogicInterfaceClassLib	104
D.4	AutomationMLPLCopenXMLInterfaceClassLib.....	105
Annex E (normative)	XML representation of AML logic XML schema.....	106
Bibliography.....		110
Figure 1 – Overview of the engineering data exchange format AML		11
Figure 2 – Example of system representation with roles of information in AML.....		17
Figure 3 – Logic models in AML		18
Figure 4 – Storing logic models in AML logic XML.....		19
Figure 5 – Modelling elements of the AML logic XML		20
Figure 6 – Model elements of Gantt charts.....		21

Figure 7 – Information provided by Gantt charts.....	22
Figure 8 – Model elements of activity-on-node networks	23
Figure 9 – Information provided by activity-on-node networks	24
Figure 10 – Model elements of timing diagrams	25
Figure 11 – Information provided by timing diagrams	26
Figure 12 – AML logic schema overview	28
Figure 13 – Root element "AMLogic"	29
Figure 14 – Complex type "FunctionBlock".....	30
Figure 15 – Complex type "ParameterSet"	31
Figure 16 – Complex type "VariableDecl"	31
Figure 17 – Complex type "IML"	32
Figure 18 – Complex type "IMLStep".....	34
Figure 19 – Complex type "IMLTransition"	34
Figure 20 – Complex type "IMLSimultaneousDivergence"	35
Figure 21 – Complex type "IMLSimultaneousConvergence"	35
Figure 22 – Complex type "MathematicalExpression"	35
Figure 23 – AutomationMLLogicRoleClassLib	58
Figure 24 – AutomationMLLogicInterfaceClassLib.....	60
Figure 25 – AutomationMLPLCOpenXMLInterfaceClassLib.....	63
Figure A.1 – Flow rate of valves.....	86
Figure A.2 – Example for storing a mathematical expression	88
Figure B.1 – Referencing logic information (as SFC) stored in one FunctionBlock.....	89
Figure B.2 – XML text of the CAEX file for referencing logic information stored in one FunctionBlock	90
Figure B.3 – Referencing logic information, which is composed of several FunctionBlocks	90
Figure B.4 – Referencing logic information which is composed of several AML logic XML documents	91
Figure B.5 – XML text of the CAEX file for referencing logic information, which is composed of several AML logic XML documents.....	91
Figure B.6 – Referencing a variable	92
Figure B.7 – XML text of the CAEX file for referencing a variable.....	92
Figure B.8 – Referencing a logic element.....	93
Figure B.9 – XML text of the CAEX file for referencing a logic element	93
Figure B.10 – Referencing a variable of an already referenced logic model.....	94
Figure B.11 – XML text of the CAEX file for referencing a variable of an already referenced logic model.....	95
Figure C.1 – Example manufacturing system	96
Figure C.2 – Example interlocking source group and interlocking target group.....	97
Figure C.3 – Referencing interlocking information without interlocking condition	98
Figure C.4 – XML text of the CAEX file for referencing interlocking information without interlocking condition	99
Figure C.5 – Referencing interlocking information with interlocking condition	100
Figure C.6 – XML text of the CAEX file for referencing interlocking information with interlocking condition	101

Figure C.7 – Linking logical interface with physical interface (extension to Figure C.5)	102
Figure C.8 – XML text of the CAEX file for linking logical interface with physical interface (extension to Figure C.6)	102
Table 1 – Abbreviated terms	16
Table 2 – Mapping the start of a Gantt chart to IML element	38
Table 3 – Mapping of Gantt chart bars to IML elements	38
Table 4 – Mapping of Gantt chart arrow to IML elements	39
Table 5 – Mapping of Gantt chart bar with one or more successor bars to IML elements	40
Table 6 – Mapping of Gantt chart bar with one and more predecessor bars to IML elements	41
Table 7 – Mapping of the start of an activity-on-node network to IML elements	42
Table 8 – Mapping of activity-on-node network nodes to IML elements	43
Table 9 – Mapping of activity-on-node network arrows to IML elements	44
Table 10 – Mapping of activity-on-node network successor nodes to IML elements	44
Table 11 – Mapping of activity-on-node network predecessor nodes to IML elements	45
Table 12 – Mapping of the timeline of a timing diagram to IML elements	48
Table 13 – Mapping of timing diagram resources and resource states to IML elements	48
Table 14 – Mapping of timing diagram lifelines to IML elements	49
Table 15 – Mapping of the time signal and the resource signal to IML elements	51
Table 16 – Storing variable of a sequential function chart in AML logic XML	53
Table 17 – Storing variable of a function block diagram in AML logic XML	54
Table 18 – Storing variable of a mathematical expression in AML logic XML	55
Table 19 – Storing variable mappings of a mathematical expression in AML logic XML	56
Table 20 – Storing a mathematical expression in AML logic XML	56
Table 21 – Meta information about each AML logic XML writer tool	57
Table 22 – RoleClass InterlockingTargetGroup	58
Table 23 – RoleClass InterlockingSourceGroup	59
Table 24 – RoleClass LogicModelObject	59
Table 25 – InterfaceClass LogicModelInterface	60
Table 26 – InterfaceClass SequencingLogicModelInterface	61
Table 27 – InterfaceClass BehaviourLogicModelInterface	61
Table 28 – InterfaceClass InterlockingLogicModelInterface	61
Table 29 – InterfaceClass LogicModelElementInterface	62
Table 30 – InterfaceClass VariableInterface	62
Table 31 – InterfaceClass InterlockingVariableInterface	63
Table 32 – InterfaceClass VariableInterface	63
Table 33 – InterfaceClass InterlockingConnector	64
Table 34 – InterfaceClass PLCOpenXMLInterface	64
Table A.1 – Storing of the Gantt chart example "activities without predecessor and successor relations"	68
Table A.2 – Storing of the Gantt chart example "activity sequence"	69
Table A.3 – Storing of the Gantt chart example "activity sequence with divergence"	70
Table A.4 – Storing of the Gantt chart example "activity sequence with convergences"	71

Table A.5 – Storing of the activity-on-node network example "activities without predecessor and successor relations"	72
Table A.6 – Storing of the activity-on-node network example "activity sequence"	73
Table A.7 – Storing of the activity-on-node network example "activity sequence with divergence"	74
Table A.8 – Storing of the activity-on-node network example "activity sequence with convergences"	75
Table A.9 – Storing of the timing diagram example "transition from a state change to the subsequent state"	77
Table A.10 – Mapping of the timing diagram example "two external signals fired with delay of three seconds"	78
Table A.11 – Storing of the timing diagram example "signal fired by one resource state and consumed by another"	80
Table A.12 – Example for storing sequential function chart	81
Table A.13 – Example for storing a function block diagram	83

INTERNATIONAL ELECTROTECHNICAL COMMISSION

**ENGINEERING DATA EXCHANGE FORMAT FOR USE
IN INDUSTRIAL AUTOMATION SYSTEMS ENGINEERING –
AUTOMATION MARKUP LANGUAGE –**

Part 4: Logic

FOREWORD

- 1) The International Electrotechnical Commission (IEC) is a worldwide organization for standardization comprising all national electrotechnical committees (IEC National Committees). The object of IEC is to promote international co-operation on all questions concerning standardization in the electrical and electronic fields. To this end and in addition to other activities, IEC publishes International Standards, Technical Specifications, Technical Reports, Publicly Available Specifications (PAS) and Guides (hereafter referred to as "IEC Publication(s)"). Their preparation is entrusted to technical committees; any IEC National Committee interested in the subject dealt with may participate in this preparatory work. International, governmental and non-governmental organizations liaising with the IEC also participate in this preparation. IEC collaborates closely with the International Organization for Standardization (ISO) in accordance with conditions determined by agreement between the two organizations.
- 2) The formal decisions or agreements of IEC on technical matters express, as nearly as possible, an international consensus of opinion on the relevant subjects since each technical committee has representation from all interested IEC National Committees.
- 3) IEC Publications have the form of recommendations for international use and are accepted by IEC National Committees in that sense. While all reasonable efforts are made to ensure that the technical content of IEC Publications is accurate, IEC cannot be held responsible for the way in which they are used or for any misinterpretation by any end user.
- 4) In order to promote international uniformity, IEC National Committees undertake to apply IEC Publications transparently to the maximum extent possible in their national and regional publications. Any divergence between any IEC Publication and the corresponding national or regional publication shall be clearly indicated in the latter.
- 5) IEC itself does not provide any attestation of conformity. Independent certification bodies provide conformity assessment services and, in some areas, access to IEC marks of conformity. IEC is not responsible for any services carried out by independent certification bodies.
- 6) All users should ensure that they have the latest edition of this publication.
- 7) No liability shall attach to IEC or its directors, employees, servants or agents including individual experts and members of its technical committees and IEC National Committees for any personal injury, property damage or other damage of any nature whatsoever, whether direct or indirect, or for costs (including legal fees) and expenses arising out of the publication, use of, or reliance upon, this IEC Publication or any other IEC Publications.
- 8) Attention is drawn to the Normative references cited in this publication. Use of the referenced publications is indispensable for the correct application of this publication.
- 9) Attention is drawn to the possibility that some of the elements of this IEC Publication may be the subject of patent rights. IEC shall not be held responsible for identifying any or all such patent rights.

International Standard IEC 62714-4 has been prepared by subcommittee 65E: Devices and integration in enterprise systems, of IEC technical committee 65: Industrial-process measurement, control and automation.

The text of this International Standard is based on the following documents:

CDV	Report on voting
65E/654/CDV	65E/692/RVC

Full information on the voting for the approval of this International Standard can be found in the report on voting indicated in the above table.

This document has been drafted in accordance with the ISO/IEC Directives, Part 2.

A list of all parts in the IEC 62714 series, published under the general title *Engineering data exchange format for use in industrial systems engineering – Automation Markup Language*, can be found on the IEC website.

The committee has decided that the contents of this document will remain unchanged until the stability date indicated on the IEC website under "<http://webstore.iec.ch>" in the data related to the specific document. At this date, the document will be

- reconfirmed,
- withdrawn,
- replaced by a revised edition, or
- amended.

IMPORTANT – The 'colour inside' logo on the cover page of this publication indicates that it contains colours which are considered to be useful for the correct understanding of its contents. Users should therefore print this document using a colour printer.

INTRODUCTION

The data exchange format defined in IEC 62714 (Automation Markup Language (AML)) is an XML schema-based data format and has been developed in order to support the data exchange between engineering tools in a heterogeneous engineering tool landscape. IEC 62714-1 gives an overview about the format.

The goal of AML is to interconnect engineering tools from the existing heterogeneous tool landscape in their different disciplines, e.g. mechanical plant engineering, electrical design, process engineering, process control engineering, HMI development, PLC programming, robot programming, etc.

AML stores engineering information following the object-oriented paradigm and allows modelling of physical and logical plant components as data objects encapsulating different aspects. An object may consist of other sub-objects and may itself be part of a larger composition or aggregation. Typical objects in plant automation comprise information on topology, geometry, kinematics, and logic, whereas logic comprises sequencing, behaviour, and control.

AML combines existing industry data formats that are designed for the storage and exchange of different aspects of engineering information. These data formats are used on "as-is" basis within their own specifications and are not branched for AML needs.

The core of AML is the top-level data format CAEX that connects the different data formats. Therefore, AML has an inherent distributed document architecture.

Figure 1 illustrates the basic AML architecture and the distribution of topology, geometry, kinematic, and logic information.

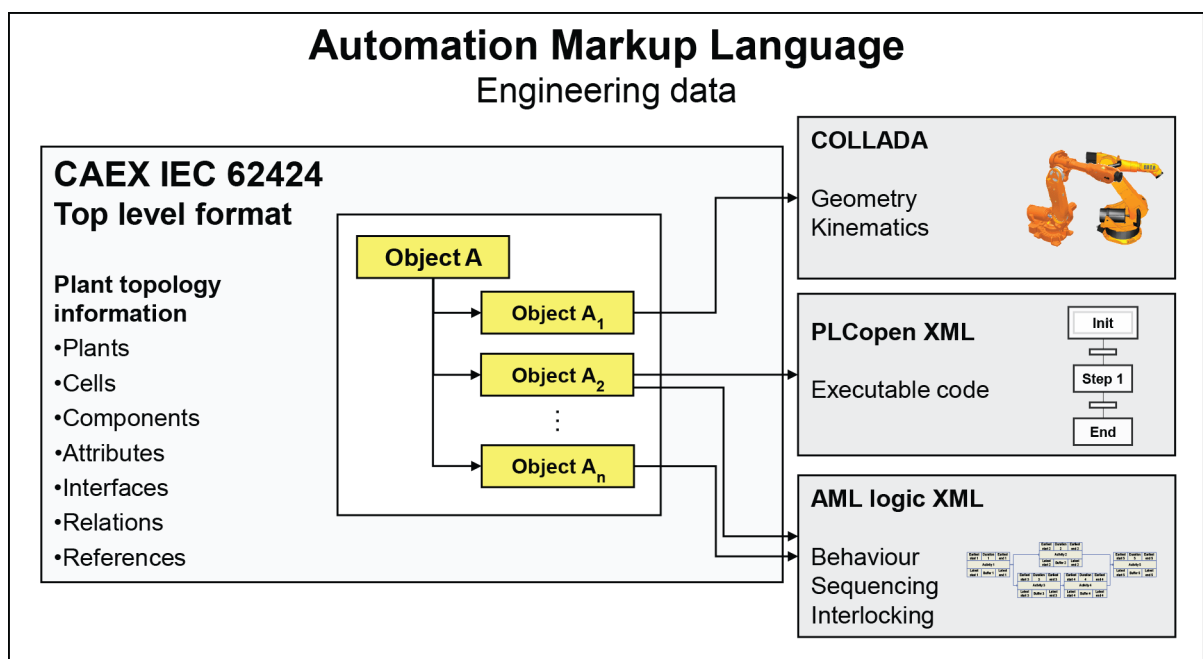

IEC

Figure 1 – Overview of the engineering data exchange format AML

Owing to the different aspects of AML, IEC 62714 consists of different parts focussing on different aspects.

- IEC 62714-1: Architecture and general requirements

This part specifies the general AML architecture, the modelling of engineering data, classes, instances, relations, references, hierarchies, basic AML libraries and extended AML concepts.

- IEC 62714-2: Role class libraries

This part specifies additional AML libraries.

- IEC 62714-3: Geometry and kinematics

This part specifies the modelling of geometry and kinematics information.

- IEC 62714-4: Logic

This part specifies the modelling and referencing of logic information.

Further parts may be added in the future in order to interconnect further data standards to AML.

Clause 5 gives an informative overview of this part of the standard.

Clause 6 gives a normative description of the considered logic models.

Clause 7 gives a normative description of the AML logic XML schema, with which logic models can be stored.

Clause 8 specifies the normative provisions to store the logic models in AML logic XML.

Clause 9 defines how to store meta information about the source tool directly into the AML logic XML document.

Clause 10 defines a logic related role class library and interface class library.

Subclause 10.4.2 gives a normative description regarding referencing logic information in AML logic XML documents.

Clause 12 gives a normative description regarding referencing interlocking information in AML logic XML documents.

Annex A provides examples for the storage of logic models in AML logic XML.

Annex B describes the referencing methods for logic information.

Annex C describes the referencing methods for interlocking information.

Annex D gives a normative XML representation of the libraries defined in this document.

Annex E gives a normative XML representation of the AML logic XML schema defined in this document.

ENGINEERING DATA EXCHANGE FORMAT FOR USE IN INDUSTRIAL AUTOMATION SYSTEMS ENGINEERING – Automation Markup Language –

Part 4: Logic

1 Scope

This part of IEC 62714 specifies the integration of logic information as part of an AML model for the data exchange in a heterogenous engineering tool landscape of production systems.

This document specifies three types of logic information: sequencing, behaviour, and interlocking information.

This document deals with the six following sequencing and behaviour logic models (covering the different phases of the engineering process of production systems) and how they are integrated in AML: Gantt chart, activity-on-node network, timing diagram, Sequential Function Chart (SFC), Function Block Diagram (FBD), and mathematical expression.

This document specifies how to model Gantt chart, activity-on-node network, and timing diagram and how they are stored in Intermediate Modelling Layer (IML).

NOTE 1 With this, it is possible to transform one logic model into another one. A forward transformation supports the information enrichment process and reduces or avoids a re-entry of information between the exchanging engineering tools.

NOTE 2 Mapping of other logic models, e.g. event-driven logic models like state charts, onto IML is possible.

This document specifies how interlocking information is modelled (as interlocking source and target groups) in AML. The interlocking logic model is stored in Function Block Diagram (FBD).

This document specifies the AML logic XML schema that stores the logic models by using IEC 61131-10.

This document specifies how to reference PLC programs stored in PLCopen XML documents.

This document does not define details of the data exchange procedure or implementation requirements for the import/export tools.

2 Normative references

The following documents are referred to in the text in such a way that some or all of their content constitutes requirements of this document. For dated references, only the edition cited applies. For undated references, the latest edition of the referenced document (including any amendments) applies.

IEC 61131-3, *Programmable controllers – Part 3: Programming languages*

IEC 61131-10, *Programmable controllers – Part 10: PLC open XML exchange format*