

# INTERNATIONAL STANDARD

---

**Wind energy generation systems –  
Part 27-1: Electrical simulation models – Generic models**





**THIS PUBLICATION IS COPYRIGHT PROTECTED**  
**Copyright © 2020 IEC, Geneva, Switzerland**

All rights reserved. Unless otherwise specified, no part of this publication may be reproduced or utilized in any form or by any means, electronic or mechanical, including photocopying and microfilm, without permission in writing from either IEC or IEC's member National Committee in the country of the requester. If you have any questions about IEC copyright or have an enquiry about obtaining additional rights to this publication, please contact the address below or your local IEC member National Committee for further information.

IEC Central Office  
3, rue de Varembe  
CH-1211 Geneva 20  
Switzerland

Tel.: +41 22 919 02 11  
[info@iec.ch](mailto:info@iec.ch)  
[www.iec.ch](http://www.iec.ch)

**About the IEC**

The International Electrotechnical Commission (IEC) is the leading global organization that prepares and publishes International Standards for all electrical, electronic and related technologies.

**About IEC publications**

The technical content of IEC publications is kept under constant review by the IEC. Please make sure that you have the latest edition, a corrigendum or an amendment might have been published.

**IEC publications search - [webstore.iec.ch/advsearchform](http://webstore.iec.ch/advsearchform)**

The advanced search enables to find IEC publications by a variety of criteria (reference number, text, technical committee,...). It also gives information on projects, replaced and withdrawn publications.

**IEC Just Published - [webstore.iec.ch/justpublished](http://webstore.iec.ch/justpublished)**

Stay up to date on all new IEC publications. Just Published details all new publications released. Available online and once a month by email.

**IEC Customer Service Centre - [webstore.iec.ch/csc](http://webstore.iec.ch/csc)**

If you wish to give us your feedback on this publication or need further assistance, please contact the Customer Service Centre: [sales@iec.ch](mailto:sales@iec.ch).

**Electropedia - [www.electropedia.org](http://www.electropedia.org)**

The world's leading online dictionary on electrotechnology, containing more than 22 000 terminological entries in English and French, with equivalent terms in 16 additional languages. Also known as the International Electrotechnical Vocabulary (IEV) online.

**IEC Glossary - [std.iec.ch/glossary](http://std.iec.ch/glossary)**

67 000 electrotechnical terminology entries in English and French extracted from the Terms and Definitions clause of IEC publications issued since 2002. Some entries have been collected from earlier publications of IEC TC 37, 77, 86 and CISPR.



IEC 61400-27-1

Edition 2.0 2020-07

# INTERNATIONAL STANDARD

---

**Wind energy generation systems –  
Part 27-1: Electrical simulation models – Generic models**

INTERNATIONAL  
ELECTROTECHNICAL  
COMMISSION

---

ICS 27.180

ISBN 978-2-8322-8505-3

**Warning! Make sure that you obtained this publication from an authorized distributor.**

## CONTENTS

FOREWORD.....	8
INTRODUCTION.....	10
1 Scope.....	12
2 Normative references .....	12
3 Terms, definitions, abbreviations and subscripts.....	12
3.1 Terms and definitions.....	12
3.2 Abbreviations and subscripts .....	16
3.2.1 Abbreviations.....	16
3.2.2 Subscripts .....	18
4 Symbols and units .....	19
4.1 General.....	19
4.2 Symbols (units).....	19
5 Functional specification of models .....	23
5.1 General specifications.....	23
5.2 Wind turbine models .....	24
5.3 Wind power plant models .....	25
6 Formal specification of modular structures of models.....	25
6.1 General.....	25
6.2 Wind turbine models .....	26
6.2.1 General .....	26
6.2.2 Type 1 .....	26
6.2.3 Type 2 .....	28
6.2.4 Type 3 .....	30
6.2.5 Type 4 .....	32
6.3 Auxiliary equipment models .....	37
6.3.1 STATCOM .....	37
6.3.2 Other auxiliary equipment.....	38
6.4 Wind power plant models .....	38
6.4.1 General .....	38
6.4.2 Wind power plant control and communication .....	39
6.4.3 Basic wind power plant.....	40
6.4.4 Wind power plant with reactive power compensation .....	41
7 Formal specification of modules .....	42
7.1 General.....	42
7.2 Aerodynamic modules.....	43
7.2.1 Constant aerodynamic torque module.....	43
7.2.2 One-dimensional aerodynamic module .....	44
7.2.3 Two-dimensional aerodynamic module .....	44
7.3 Mechanical modules .....	46
7.3.1 Two mass module.....	46
7.3.2 Other mechanical modules .....	46
7.4 Generator and converter system modules .....	46
7.4.1 Asynchronous generator module.....	46
7.4.2 Type 3A generator system module.....	47
7.4.3 Type 3B generator system module.....	48
7.4.4 Type 4 generator system module .....	49

7.4.5	Reference frame rotation module .....	50
7.5	Electrical systems modules .....	51
7.5.1	Electrical systems gamma module .....	51
7.5.2	Other electrical systems modules .....	52
7.6	Pitch control modules.....	52
7.6.1	Pitch control power module.....	52
7.6.2	Pitch angle control module.....	53
7.7	Generator and converter control modules .....	54
7.7.1	Rotor resistance control module .....	54
7.7.2	P control module type 3 .....	55
7.7.3	P control module type 4A.....	58
7.7.4	P control module type 4B.....	59
7.7.5	Q control module .....	60
7.7.6	Current limitation module.....	63
7.7.7	Constant Q limitation module.....	64
7.7.8	QP and QU limitation module.....	65
7.8	Grid interfacing modules .....	66
7.8.1	Grid protection module .....	66
7.8.2	Grid measurement module.....	67
7.9	Wind power plant control modules.....	68
7.9.1	WP P control module .....	68
7.9.2	WP Q control module.....	69
7.10	Communication modules .....	71
7.10.1	General .....	71
7.10.2	Communication delay module .....	71
7.10.3	Linear communication module .....	71
7.11	Electrical components modules.....	72
7.11.1	Line module.....	72
7.11.2	Transformer module .....	72
7.11.3	Other electrical components modules .....	72
Annex A (informative) Estimation of parameters for single branch power collection system model.....		73
A.1	General.....	73
A.2	Description of method .....	73
A.2.1	General .....	73
A.2.2	Lines aggregation .....	73
A.2.3	Wind turbine transformers aggregation .....	74
A.3	Numerical example .....	75
Annex B (informative) Two-dimensional aerodynamic model .....		78
B.1	Objective .....	78
B.2	Wind speed input model.....	78
B.3	Parameters for power input module.....	80
Annex C (informative) Implementation of generator systems modules with external impedance .....		81
Annex D (normative) Block symbol library .....		84
D.1	General.....	84
D.2	Switch.....	84
D.3	Time step delay .....	84
D.4	Stand-alone ramp rate limiter .....	85

D.5	First order filter .....	85
D.6	Lookup table .....	86
D.7	Comparator .....	86
D.8	Timer .....	87
D.9	Anti windup integrator .....	88
D.10	Integrator with reset.....	88
D.11	First order filter with limitation detection.....	89
D.12	Rising edge detection .....	89
D.13	Falling edge detection.....	90
D.14	Delay flag .....	90
D.15	Variable delay flag .....	91
D.16	Dead band .....	92
D.17	Circuit breaker .....	92
	Bibliography.....	93

Figure 1	– Classification of power system stability according to IEEE/CIGRE Joint Task Force on Stability Terms and Definitions [9].....	10
Figure 2	– Generic structure of WT models .....	26
Figure 3	– Modular structure of the type 1A WT model.....	27
Figure 4	– Modular structure of the type 1B WT model.....	28
Figure 5	– Modular structure of the type 2 WT model .....	29
Figure 6	– Modular structure of the type 3A and type 3B WT models .....	30
Figure 7	– Modular generator control sub-structure of the type 3A and type 3B models.....	31
Figure 8	– Modular structure of the type 4A WT model.....	33
Figure 9	– Modular generator control sub-structure of the type 4A model.....	34
Figure 10	– Modular structure of the type 4B WT model.....	35
Figure 11	– Modular generator control sub-structure of the type 4B model.....	36
Figure 12	– Modular structure of STATCOM model .....	37
Figure 13	– Modular structure of the STATCOM control model.....	37
Figure 14	– General structure of WP model .....	38
Figure 15	– General modular structure of WP control and communication block.....	39
Figure 16	– Single line diagram for basic WP model .....	40
Figure 17	– Single line diagram for WP model with reactive power compensation .....	41
Figure 18	– Block diagram for constant aerodynamic torque module .....	44
Figure 19	– Block diagram for one-dimensional aerodynamic module.....	44
Figure 20	– Block diagram for two-dimensional aerodynamic module .....	45
Figure 21	– Block diagram for two mass module .....	46
Figure 22	– Block diagram for type 3A generator system module .....	47
Figure 23	– Block diagram for type 3B generator system module .....	49
Figure 24	– Block diagram for type 4 generator system module .....	50
Figure 25	– Block diagram for the reference frame rotation module.....	51
Figure 26	– Single line diagram for electrical systems gamma module .....	52
Figure 27	– Block diagram for pitch control power module .....	53
Figure 28	– Block diagram for pitch angle control module .....	54
Figure 29	– Block diagram for rotor resistance control module .....	55

Figure 30 – Block diagram for type 3 P control module .....	57
Figure 31 – Block diagram for type 3 torque PI .....	58
Figure 32 – Block diagram for type 4A P control module .....	59
Figure 33 – Block diagram for type 4B P control module .....	60
Figure 34 – Block diagram for Q control module.....	62
Figure 35 – Block diagram for current limiter.....	64
Figure 36 – Block diagram for constant Q limitation module .....	65
Figure 37 – Block diagram for QP and QU limitation module .....	65
Figure 38 – Block diagram for grid protection system.....	67
Figure 39 – Block diagram for u-f measurement.....	68
Figure 40 – Block diagram for WP power/frequency control module .....	69
Figure 41 – Block diagram for WP reactive power/voltage control module .....	70
Figure 42 – Block diagram for communication delay module .....	71
Figure 43 – Block diagram for linear communication module for an example with N communication variables.....	72
Figure A.1 – WP power collection system example .....	75
Figure B.1 – Turbine aerodynamics model proposed by Fortmann (2014) .....	78
Figure C.1 – Type 3A generator system module with parallel reactance.....	81
Figure C.2 – Type 3B generator system module with parallel reactance.....	82
Figure C.3 – Type 4 generator system module with parallel reactance .....	83
Figure D.1 – Block symbol for switch with a) a variable flag input and b) a constant mode .....	84
Figure D.2 – Block symbol for single integration time step delay .....	84
Figure D.3 – Block symbol for stand-alone ramp rate limiter.....	85
Figure D.4 – Block diagram for implementation of the stand-alone ramp rate limiter.....	85
Figure D.5 – Block symbol for first order filter with absolute limits, rate limits and freeze flag .....	85
Figure D.6 – Block diagram for implementation of the first order filter with absolute limits, rate limits and freeze state.....	86
Figure D.7 – Block diagram for implementation of the freeze state without filter ( $T = 0$ ).....	86
Figure D.8 – Block symbol for lookup table .....	86
Figure D.9 – Block symbols for comparators .....	87
Figure D.10 – Block symbol for timer .....	87
Figure D.11 – Function of timer.....	87
Figure D.12 – Block symbol for anti windup integrator.....	88
Figure D.13 – Block diagram for implementation of anti windup integrator.....	88
Figure D.14 – Block symbol for integrator with reset .....	88
Figure D.15 – Block symbol for first order filter with limitation detection .....	89
Figure D.16 – Block diagram for implementation of first order filter with limitation detection.....	89
Figure D.17 – Block symbol rising edge detection .....	89
Figure D.18 – Block diagram for rising edge detection .....	90
Figure D.19 – Block symbol falling edge detection .....	90
Figure D.20 – Block diagram for falling edge detection .....	90
Figure D.21 – Block symbol for delay flag .....	90

Figure D.22 – Block diagram for implementation of delay flag .....	91
Figure D.23 – Block symbol for delay flag .....	91
Figure D.24 – Block diagram for implementation of variable delay flag .....	92
Figure D.25 – Block symbol dead band .....	92
Figure D.26 – Block symbol for circuit breaker .....	92
Table 1 – Modules used in type 1A model .....	27
Table 2 – Modules used in type 1B model .....	28
Table 3 – Modules used in type 2 model .....	29
Table 4 – Modules used in type 3A model .....	31
Table 5 – Modules used in type 3B model .....	32
Table 6 – Modules used in type 4A model .....	34
Table 7 – Modules used in type 4B model .....	36
Table 8 – Modules used in STATCOM model .....	38
Table 9 – Modules used in WP control and communication model .....	40
Table 10 – Models and additional modules used in the basic WP model .....	41
Table 11 – Models and modules used in the WP model with reactive power compensation .....	42
Table 12 – Global model parameters .....	42
Table 13 – Initialisation variable used in module block diagrams .....	43
Table 14 – Parameter list for one-dimensional aerodynamic module .....	44
Table 15 – Parameter list for two-dimensional aerodynamic module .....	45
Table 16 – Parameter list for two-mass module .....	46
Table 17 – Parameter list for type 3A generator system module .....	47
Table 18 – Parameter list for type 3B generator system module .....	48
Table 19 – Parameter list for type 4 generator system module .....	50
Table 20 – Parameter list for reference frame rotation module .....	50
Table 21 – Parameter list for electrical systems gamma module .....	51
Table 22 – Parameter list for pitch control power module .....	52
Table 23 – Parameter list for pitch angle control module .....	53
Table 24 – Parameter list for rotor resistance control module .....	54
Table 25 – Parameter list for P control module type 3 .....	55
Table 26 – Parameter list for P control module type 4A .....	58
Table 27 – Parameter list for P control module type 4B .....	59
Table 28 – General WT Q control modes $M_{qG}$ .....	60
Table 29 – Reactive current injection for each FRT Q control modes $M_{qFRT}$ .....	60
Table 30 – Parameter list for Q control module .....	61
Table 31 – Description of $F_{FRT}$ flag values .....	63
Table 32 – Parameter list for current limiter module .....	63
Table 33 – Parameter list for constant Q limitation module .....	64
Table 34 – Parameter list for QP and QU limitation module .....	65
Table 35 – Parameter list for grid protection module .....	66
Table 36 – Parameter list for grid measurement module .....	67

Table 37 – Parameter list for power/frequency control module ..... 68

Table 38 – Parameter list for reactive power/voltage control module ..... 69

Table 39 – Parameter list for communication delay module ..... 71

Table 40 – Parameter list for linear communication module..... 71

Table A.1 – Lines parameters and aggregation calculations. The data is in per-units  
using WP base values ..... 76

Table A.2 – Transformers parameters ..... 76

Table A.3 – Estimated parameters for the single branch collection system model in  
6.4.3 ..... 77

Table B.1 – Lookup table specifying the function  $\partial p_{\omega}(v_0)$ ..... 79

Table B.2 – Parameter list for the wind speed input model ..... 79

## INTERNATIONAL ELECTROTECHNICAL COMMISSION

**WIND ENERGY GENERATION SYSTEMS –****Part 27-1: Electrical simulation models –  
Generic models****FOREWORD**

- 1) The International Electrotechnical Commission (IEC) is a worldwide organization for standardization comprising all national electrotechnical committees (IEC National Committees). The object of IEC is to promote international co-operation on all questions concerning standardization in the electrical and electronic fields. To this end and in addition to other activities, IEC publishes International Standards, Technical Specifications, Technical Reports, Publicly Available Specifications (PAS) and Guides (hereafter referred to as "IEC Publication(s)"). Their preparation is entrusted to technical committees; any IEC National Committee interested in the subject dealt with may participate in this preparatory work. International, governmental and non-governmental organizations liaising with the IEC also participate in this preparation. IEC collaborates closely with the International Organization for Standardization (ISO) in accordance with conditions determined by agreement between the two organizations.
- 2) The formal decisions or agreements of IEC on technical matters express, as nearly as possible, an international consensus of opinion on the relevant subjects since each technical committee has representation from all interested IEC National Committees.
- 3) IEC Publications have the form of recommendations for international use and are accepted by IEC National Committees in that sense. While all reasonable efforts are made to ensure that the technical content of IEC Publications is accurate, IEC cannot be held responsible for the way in which they are used or for any misinterpretation by any end user.
- 4) In order to promote international uniformity, IEC National Committees undertake to apply IEC Publications transparently to the maximum extent possible in their national and regional publications. Any divergence between any IEC Publication and the corresponding national or regional publication shall be clearly indicated in the latter.
- 5) IEC itself does not provide any attestation of conformity. Independent certification bodies provide conformity assessment services and, in some areas, access to IEC marks of conformity. IEC is not responsible for any services carried out by independent certification bodies.
- 6) All users should ensure that they have the latest edition of this publication.
- 7) No liability shall attach to IEC or its directors, employees, servants or agents including individual experts and members of its technical committees and IEC National Committees for any personal injury, property damage or other damage of any nature whatsoever, whether direct or indirect, or for costs (including legal fees) and expenses arising out of the publication, use of, or reliance upon, this IEC Publication or any other IEC Publications.
- 8) Attention is drawn to the Normative references cited in this publication. Use of the referenced publications is indispensable for the correct application of this publication.
- 9) Attention is drawn to the possibility that some of the elements of this IEC Publication may be the subject of patent rights. IEC shall not be held responsible for identifying any or all such patent rights.

International Standard IEC 61400-27-1 has been prepared by IEC technical committee 88: Wind energy generation systems.

This document has been drafted in accordance with the ISO/IEC Directives, Part 2.

The text of this International Standard is based on the following documents:

FDIS	Report on voting
88/762/FDIS	88/771/RVD

Full information on the voting for the approval of this International Standard can be found in the report on voting indicated in the above table.

This publication has been drafted in accordance with the ISO/IEC Directives, Part 2.

This second edition cancels and replaces the first edition, published in 2015. This edition constitutes a technical revision and a restructure of the content into two parts. The new structure joins the models in part 27-1 and the validation procedures in part 27-2.

This edition includes the following significant technical changes with respect to the previous edition:

- a) "Wind turbines" changed to "Generic models" because wind power plant models are also included, and the model validation is moved to IEC 61400-27-2;
- b) specification of models for wind power plants including plant control, communication system model and aggregation procedure for power collection system in addition to the wind turbine models in the previous edition;
- c) moving validation procedures for wind turbine models from this edition to part 27-2;
- d) a more detailed modular structure separating wind turbine control into pitch control and generator system control and extracting grid measurement modules from the control modules. Figures are revised accordingly;
- e) inclusion of model for STATCOM;
- f) inclusion of electrical components modules.

A list of all parts in the IEC 61400, published under the general title *Wind energy generation systems*, can be found on the IEC website.

Future standards in this series will carry the new general title as cited above. Titles of existing standards in this series will be updated at the time of the next edition.

The committee has decided that the contents of this publication will remain unchanged until the stability date indicated on the IEC web site under "<http://webstore.iec.ch>" in the data related to the specific publication. At this date, the publication will be

- reconfirmed,
- withdrawn,
- replaced by a revised edition, or
- amended.

## INTRODUCTION

IEC 61400-27-1 specifies standard dynamic electrical simulation models for wind turbines and wind power plants. The specified wind turbine models can either be used in wind power plant models or to represent wind turbines without wind power plant relationships. Apart from the wind turbine models, the wind power plant model may include models for auxiliary equipment such as STATCOMs which are often used in wind power plants.

The increasing penetration of wind energy in power systems implies that Transmission System Operators (TSOs) and Distribution System Operators (DSOs) need to use dynamic models of wind power generation for power system stability studies. The models developed by the wind turbine manufacturers reproduce the behaviour of their machines with a high level of detail. Such level of detail is not suitable for stability studies of large power systems with a huge number of wind power plants, firstly because the high level of detail increases the complexity and thus computer time dramatically, and secondly because the use of detailed manufacturer specific models requires a substantial amount of input data to represent the individual wind turbine types.

The purpose of this International Standard is to specify generic dynamic models, which can be applied in power system stability studies. The IEEE/CIGRE Joint Task Force on Stability Terms and Definitions [11]<sup>1</sup> has classified power system stability in categories according to Figure 1.

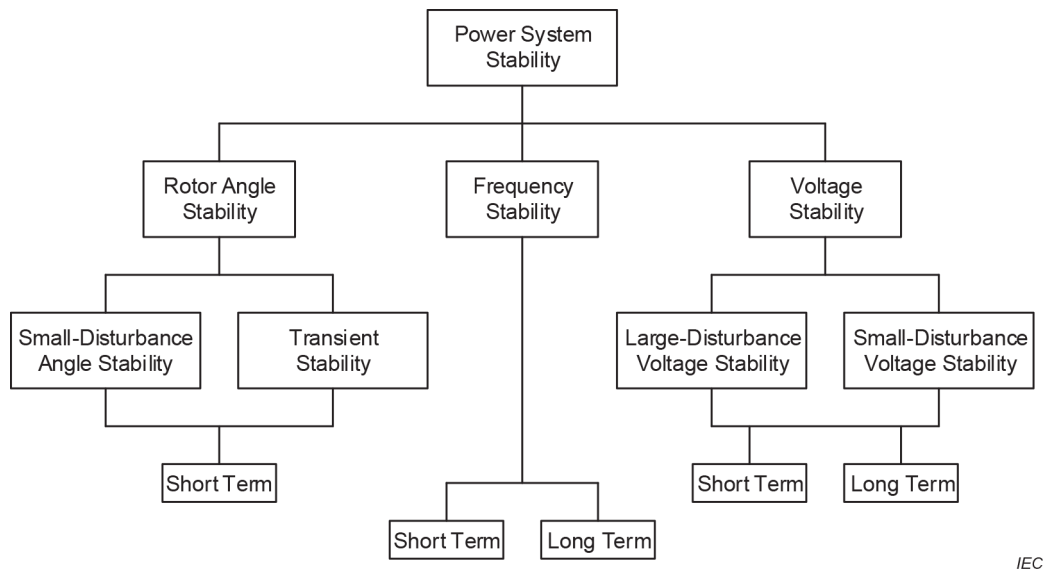

**Figure 1 – Classification of power system stability according to IEEE/CIGRE Joint Task Force on Stability Terms and Definitions [11]**

Referring to these categories, the models are developed to represent wind power generation in studies of large-disturbance short term stability phenomena, i.e. short term voltage stability, short term frequency stability and short term transient stability studies referring to the definitions of IEEE/CIGRE Joint Task Force on Stability Terms and Definitions in Figure 1. Thus, the models are applicable for dynamic simulations of power system events such as short-circuits (low voltage ride through), loss of generation or loads [12], and system separation of a synchronous system into more synchronous areas.

<sup>1</sup> The numbers in square brackets refer to the Bibliography.

The models shall be complete enough to represent the dynamic behavior of the wind power plant at the point of connection and of the wind turbine at the wind turbine terminals, but shall also be suitable for large-scale grid studies. Therefore, simplified models are specified to perform the typical response of known technologies.

The wind power plant models specified in this document are for fundamental frequency positive sequence response<sup>2</sup>.

The models have the following limitations:

- The models are not intended for long term stability analysis.
- The models are not intended for investigation of sub-synchronous interaction phenomena.
- The models are not intended for investigation of the fluctuations originating from wind speed variability in time and space. This implies that the models do not include phenomena such as turbulence, tower shadow, wind shear and wakes.
- The models do not cover phenomena such as harmonics, flicker or any other EMC emissions included in the IEC 61000 series.
- The wind generation systems are highly non-linear and simplifications have been made in the development of the models. Thus, linearisation for eigenvalue analysis is not trivial nor necessarily appropriate based on these simplified models.
- This document does not address the specifics of short-circuit calculations.
- The models are not applicable to studies where wind turbines are islanded without synchronous generation.
- The models are not intended for studies of situations with short-circuit ratios less than 3. The short circuit limitation depends on wind turbine types, control modes and other settings. The WT manufacturer can specify a lower limit for the applicable short-circuit ratio provided that this application is validated according to part 27-2.
- The models are limited by the functional specifications in Clause 5.

The following stakeholders are potential users of the models specified in this document:

- TSOs and DSOs are end users of the models, performing power system stability studies as part of the planning as well as the operation of the power systems.
- Wind plant owners are typically responsible to provide the wind power plant models to TSO and/or DSO prior to plant commissioning.
- Wind turbine manufacturers will typically provide the wind turbine models to the owner.
- Developers of modern software for power system simulation tools will use the standard to implement standard wind power models as part of the software library.
- Certification bodies in case of independent wind turbine model validation.
- Consultants who use models on behalf of TSOs, DSOs and/or wind plant developers.
- Education and research communities, who can also benefit from the generic models, as the manufacturer specific models are typically confidential.

---

<sup>2</sup> This document is dealing with balanced as well as unbalanced faults, but for unbalanced faults, only the positive sequence components are specified.

## **WIND ENERGY GENERATION SYSTEMS –**

### **Part 27-1: Electrical simulation models – Generic models**

#### **1 Scope**

This part of IEC 61400 defines standard electrical simulation models for wind turbines and wind power plants. The specified models are time domain positive sequence simulation models, intended to be used in power system and grid stability analyses. The models are applicable for dynamic simulations of short term stability in power systems.

This document defines the generic terms and parameters for the electrical simulation models.

This document specifies electrical simulation models for the generic wind power plant topologies / configurations currently on the market. The wind power plant models include wind turbines, wind power plant control and auxiliary equipment. The wind power plant models are described in a modular way which can be applied for future wind power plant concepts and with different wind turbine concepts.

This document specifies electrical simulation models for the generic wind turbine topologies/concepts/configurations currently on the market. The purpose of the models is to specify the electrical characteristics of a wind turbine at the wind turbine terminals. The wind turbine models are described in a modular way which can be applied for future wind turbine concepts. The specified wind turbine models can either be used in wind power plant models or to represent wind turbines without wind power plant relationships.

The electrical simulation models specified in IEC 61400-27-1 are independent of any software simulation tool.

#### **2 Normative references**

The following documents are referred to in the text in such a way that some or all of their content constitutes requirements of this document. For dated references, only the edition cited applies. For undated references, the latest edition of the referenced document (including any amendments) applies.

IEC 60050-415:1999, *International Electrotechnical Vocabulary (IEV) – Part 415: Wind turbine generator systems* (available at [www.electropedia.org](http://www.electropedia.org))

IEC 61970-301, *Energy management system application program interface (EMS-API) – Part 301: Common information model (CIM) base*

IEC 61970-302, *Energy management system application program interface (EMS-API) – Part 302: Common information model (CIM) dynamics*

#### **3 Terms, definitions, abbreviations and subscripts**

##### **3.1 Terms and definitions**

For the purposes of this document, the terms and definitions given in IEC 60050-415 and the following apply.