

# INTERNATIONAL STANDARD

# NORME INTERNATIONALE



---

**Industrial networks – Single-drop digital communication interface –  
Part 2: Functional safety extensions**

**Réseaux industriels – Interface de communication numérique point à point –  
Partie 2: Extensions de sécurité fonctionnelle**



**THIS PUBLICATION IS COPYRIGHT PROTECTED**  
**Copyright © 2022 IEC, Geneva, Switzerland**

All rights reserved. Unless otherwise specified, no part of this publication may be reproduced or utilized in any form or by any means, electronic or mechanical, including photocopying and microfilm, without permission in writing from either IEC or IEC's member National Committee in the country of the requester. If you have any questions about IEC copyright or have an enquiry about obtaining additional rights to this publication, please contact the address below or your local IEC member National Committee for further information.

Droits de reproduction réservés. Sauf indication contraire, aucune partie de cette publication ne peut être reproduite ni utilisée sous quelque forme que ce soit et par aucun procédé, électronique ou mécanique, y compris la photocopie et les microfilms, sans l'accord écrit de l'IEC ou du Comité national de l'IEC du pays du demandeur. Si vous avez des questions sur le copyright de l'IEC ou si vous désirez obtenir des droits supplémentaires sur cette publication, utilisez les coordonnées ci-après ou contactez le Comité national de l'IEC de votre pays de résidence.

IEC Secretariat  
3, rue de Varembe  
CH-1211 Geneva 20  
Switzerland

Tel.: +41 22 919 02 11  
[info@iec.ch](mailto:info@iec.ch)  
[www.iec.ch](http://www.iec.ch)

#### **About the IEC**

The International Electrotechnical Commission (IEC) is the leading global organization that prepares and publishes International Standards for all electrical, electronic and related technologies.

#### **About IEC publications**

The technical content of IEC publications is kept under constant review by the IEC. Please make sure that you have the latest edition, a corrigendum or an amendment might have been published.

#### **IEC publications search - [webstore.iec.ch/advsearchform](http://webstore.iec.ch/advsearchform)**

The advanced search enables to find IEC publications by a variety of criteria (reference number, text, technical committee, ...). It also gives information on projects, replaced and withdrawn publications.

#### **IEC Just Published - [webstore.iec.ch/justpublished](http://webstore.iec.ch/justpublished)**

Stay up to date on all new IEC publications. Just Published details all new publications released. Available online and once a month by email.

#### **IEC Customer Service Centre - [webstore.iec.ch/csc](http://webstore.iec.ch/csc)**

If you wish to give us your feedback on this publication or need further assistance, please contact the Customer Service Centre: [sales@iec.ch](mailto:sales@iec.ch).

#### **IEC Products & Services Portal - [products.iec.ch](http://products.iec.ch)**

Discover our powerful search engine and read freely all the publications previews. With a subscription you will always have access to up to date content tailored to your needs.

#### **Electropedia - [www.electropedia.org](http://www.electropedia.org)**

The world's leading online dictionary on electrotechnology, containing more than 22 300 terminological entries in English and French, with equivalent terms in 19 additional languages. Also known as the International Electrotechnical Vocabulary (IEV) online.

---

#### **A propos de l'IEC**

La Commission Electrotechnique Internationale (IEC) est la première organisation mondiale qui élabore et publie des Normes internationales pour tout ce qui a trait à l'électricité, à l'électronique et aux technologies apparentées.

#### **A propos des publications IEC**

Le contenu technique des publications IEC est constamment revu. Veuillez vous assurer que vous possédez l'édition la plus récente, un corrigendum ou amendement peut avoir été publié.

#### **Recherche de publications IEC -**

#### **[webstore.iec.ch/advsearchform](http://webstore.iec.ch/advsearchform)**

La recherche avancée permet de trouver des publications IEC en utilisant différents critères (numéro de référence, texte, comité d'études, ...). Elle donne aussi des informations sur les projets et les publications remplacées ou retirées.

#### **IEC Just Published - [webstore.iec.ch/justpublished](http://webstore.iec.ch/justpublished)**

Restez informé sur les nouvelles publications IEC. Just Published détaille les nouvelles publications parues. Disponible en ligne et une fois par mois par email.

#### **Service Clients - [webstore.iec.ch/csc](http://webstore.iec.ch/csc)**

Si vous désirez nous donner des commentaires sur cette publication ou si vous avez des questions contactez-nous: [sales@iec.ch](mailto:sales@iec.ch).

#### **IEC Products & Services Portal - [products.iec.ch](http://products.iec.ch)**

Découvrez notre puissant moteur de recherche et consultez gratuitement tous les aperçus des publications. Avec un abonnement, vous aurez toujours accès à un contenu à jour adapté à vos besoins.

#### **Electropedia - [www.electropedia.org](http://www.electropedia.org)**

Le premier dictionnaire d'électrotechnologie en ligne au monde, avec plus de 22 300 articles terminologiques en anglais et en français, ainsi que les termes équivalents dans 19 langues additionnelles. Egalement appelé Vocabulaire Electrotechnique International (IEV) en ligne.

# INTERNATIONAL STANDARD

# NORME INTERNATIONALE



---

**Industrial networks – Single-drop digital communication interface –  
Part 2: Functional safety extensions**

**Réseaux industriels – Interface de communication numérique point à point –  
Partie 2: Extensions de sécurité fonctionnelle**

INTERNATIONAL  
ELECTROTECHNICAL  
COMMISSION

COMMISSION  
ELECTROTECHNIQUE  
INTERNATIONALE

---

ICS 25.040

ISBN 978-2-8322-3946-9

**Warning! Make sure that you obtained this publication from an authorized distributor.  
Attention! Veuillez vous assurer que vous avez obtenu cette publication via un distributeur agréé.**

## CONTENTS

FOREWORD.....	12
INTRODUCTION.....	14
1 Scope.....	17
2 Normative references .....	17
3 Terms, definitions, symbols, abbreviated terms, and conventions .....	18
3.1 Terms and definitions.....	18
3.2 Common terms and definitions .....	18
3.3 Terms and definitions related to SDCI-FS .....	21
3.4 Symbols and abbreviated terms .....	23
3.5 Conventions.....	24
3.5.1 Behavioral descriptions.....	24
3.5.2 Memory and transmission octet order .....	25
4 Overview of SDCI-FS .....	25
4.1 Purpose of the technology and feature levels .....	25
4.1.1 Base SDCI-FS technology .....	25
4.1.2 From "analog" and "switching" to communication .....	26
4.1.3 Minimized paradigm shift from FS-DI to FS-Master .....	27
4.1.4 Following the SDCI paradigm (SIO vs. OSSDe) .....	28
4.1.5 Port class B .....	30
4.1.6 "USB-Master" with safety parameterization.....	31
4.1.7 Interoperability matrix of safety devices .....	31
4.2 Positioning within the automation hierarchy .....	32
4.3 Wiring, connectors, and power supply .....	33
4.4 Relationship to SDCI.....	33
4.5 Communication features and interfaces .....	34
4.6 Parameterization.....	34
4.7 Role of FS-Master and FS-Gateway.....	35
4.8 Mapping to upper-level systems.....	35
4.9 Structure of the document.....	35
5 Extensions to the Physical Layer (PL).....	35
5.1 Overview.....	35
5.2 Extensions to PL services .....	36
5.2.1 PL_SetMode.....	36
5.2.2 PL_Ready.....	36
5.3 Transmitter/receiver.....	37
5.3.1 Assumptions for the expansion to OSSDe.....	37
5.3.2 OSSDe specifics.....	37
5.3.3 Start-up of an FS-Device (Ready pulse).....	40
5.3.4 Electric characteristics of a receiver in FS-Device and FS-Master.....	41
5.4 Electric and dynamic characteristics of an FS-Device .....	41
5.5 Electric and dynamic characteristics of an FS-Master port (OSSDe) .....	44
5.6 FS-Master port FS-DI interface .....	45
5.7 Wake-up coordination .....	45
5.8 Fast start-up .....	46
5.9 Power supply .....	46
5.10 Medium.....	47

5.10.1	Constraints .....	47
5.10.2	Connectors .....	47
5.10.3	Cable characteristics .....	47
6	Extensions to SIO .....	47
7	Extensions to the data link layer (DL) .....	47
7.1	Overview .....	47
7.2	State machine of the FS-Master DL-mode handler .....	47
7.3	State machine of the FS-Device DL-mode handler .....	49
8	Extensions to the Master Configuration Manager (CM) .....	51
9	Extensions of the FS-Device .....	52
9.1	Principle architecture and models .....	52
9.1.1	FS-Device architecture .....	52
9.1.2	FS-Device model .....	53
9.2	Parameter Manager (PM) .....	54
9.3	Process Data Exchange (PDE) .....	54
9.4	Data Storage (DS) .....	54
9.4.1	General considerations and extensions including safety .....	54
9.4.2	Backup levels .....	55
10	Extensions of the FS-Master .....	55
10.1	Principle architecture .....	55
10.2	SMI service extensions .....	56
10.2.1	Overview .....	56
10.2.2	SMI_FSMasterAccess .....	58
10.2.3	SMI_SPDUIn .....	60
10.2.4	SMI_SPDUOut .....	60
10.2.5	SMI_FSPDInOut .....	60
10.3	ArgBlock extensions .....	62
10.3.1	Overview .....	62
10.3.2	FSMasterAccess .....	62
10.3.3	FSCPAAuthenticity .....	63
10.3.4	FSPortConfigList .....	63
10.3.5	FSPortStatusList .....	66
10.3.6	SPDUIn .....	67
10.3.7	SPDUOut .....	67
10.3.8	FSPDInOut .....	68
10.4	Safety Layer Manager (SLM) .....	69
10.4.1	Purpose .....	69
10.4.2	FS_PortModes .....	69
10.4.3	FSP parameter .....	69
10.5	Process Data Exchange (PDE) .....	73
10.6	Data Storage (DS) .....	74
11	Safety communication layer (SCL) .....	74
11.1	Functional requirements .....	74
11.2	Communication errors and safety measures .....	74
11.3	SCL services .....	75
11.3.1	Positioning of safety communication layers (SCL) .....	75
11.3.2	FS-Master SCL services .....	76
11.3.3	FS-Device SCL services .....	77

11.4	SCL protocol.....	79
11.4.1	Protocol phases to consider.....	79
11.4.2	FS-Device faults.....	80
11.4.3	Safety PDU (SPDU).....	80
11.4.4	FS-Input and FS-Output data.....	81
11.4.5	Port number.....	81
11.4.6	Status and control.....	81
11.4.7	CRC signature.....	82
11.4.8	TADI safety considerations (informative).....	83
11.4.9	Data types for SDCI-FS.....	84
11.5	SCL behavior.....	85
11.5.1	General.....	85
11.5.2	SCL state machine of the FS-Master.....	85
11.5.3	SCL state machine of the FS-Device.....	88
11.5.4	Sequence charts for several use cases.....	91
11.5.5	Monitoring of safety times.....	98
11.5.6	Reaction in the event of a malfunction.....	99
11.5.7	Start-up (communication).....	101
11.6	SCL management.....	101
11.6.1	Parameter overview (FSP and FST).....	101
11.6.2	Parameterization approaches.....	103
11.7	Integrity measures.....	104
11.7.1	IODD integrity.....	104
11.7.2	Tool integrity.....	104
11.7.3	Transmission integrity.....	104
11.7.4	Verification record.....	104
11.7.5	Authentication.....	105
11.7.6	Storage integrity.....	105
11.7.7	FS I/O data structure integrity.....	106
11.7.8	Technology parameter (FST) based on IODD.....	106
11.7.9	Technology parameter (FST) based on existing Dedicated Tool (IOPD).....	107
11.8	Creation of FSP and FST parameters.....	108
11.9	Integration of Dedicated Tools (IOPD).....	109
11.9.1	IOPD interface.....	109
11.9.2	Standard interfaces.....	109
11.9.3	Backward channel.....	110
11.10	Validation.....	111
11.11	Passivation.....	111
11.11.1	Motivation and means.....	111
11.11.2	Port selective (FS-Master).....	111
11.11.3	Signal selective (FS-Terminal).....	112
11.11.4	Qualifier settings in case of communication.....	112
11.11.5	Qualifier handling in case of OSSDe.....	112
11.12	SCL diagnosis.....	113
12	Functional safe processing (FS-P).....	114
12.1	Recommendations for efficient I/O mappings.....	114
12.2	Embedded FS controller.....	114
Annex A	(normative) Extensions to parameters.....	115
A.1	Indices and parameters for SDCI-FS.....	115

A.2	Parameters in detail.....	116
A.2.1	FSP_Authenticity.....	116
A.2.2	FSP_Port.....	116
A.2.3	FSP_AuthentCRC.....	117
A.2.4	FSP_ProtVersion.....	117
A.2.5	FSP_ProtMode.....	117
A.2.6	FSP_Watchdog.....	117
A.2.7	FSP_IO_StructCRC.....	118
A.2.8	FSP_TechParCRC.....	119
A.2.9	FSP_ProtParCRC.....	119
A.2.10	FSP_VerifyRecord.....	119
A.2.11	FSP_TimeToReady.....	119
A.2.12	FSP_MinShutDownTime.....	120
A.2.13	FSP_WCDT.....	120
A.2.14	FSP_OFDT.....	120
A.2.15	FSP_ParamDescCRC.....	120
Annex B (normative)	Extensions to EventCodes.....	121
B.1	Additional FS-Device EventCodes.....	121
B.2	Additional Port EventCodes.....	121
Annex C (normative)	Extensions to Data Types.....	123
C.1	Data types for SDCI-FS.....	123
C.2	BooleanT (bit).....	123
C.3	IntegerT (16).....	124
C.4	IntegerT (32).....	124
C.5	Safety Code.....	125
Annex D (normative)	CRC generator polynomials.....	126
D.1	Overview of CRC generator polynomials.....	126
D.2	Residual error probabilities.....	126
D.3	Implementation considerations.....	128
D.3.1	Overview.....	128
D.3.2	Bit shift algorithm (16 bit).....	128
D.3.3	Lookup table (16 bit).....	128
D.3.4	Bit shift algorithm (32 bit).....	130
D.3.5	Lookup table (32 bit).....	130
D.3.6	Seed values.....	131
D.3.7	Octet order for CRC calculation.....	132
Annex E (normative)	IODD extensions.....	133
E.1	General.....	133
E.2	Schema.....	133
E.3	IODD constraints.....	133
E.3.1	General rules.....	133
E.3.2	Description of the IODD structure.....	133
E.3.3	Behavior of "Reset" SystemCommands in SDCI-FS.....	140
E.3.4	Profile Characteristic.....	141
E.3.5	ProcessDataInput and ProcessDataOutput.....	141
E.4	IODD conventions.....	141
E.4.1	Naming.....	141
E.4.2	Process Data (PD).....	141

E.4.3	IODD conventions for user interface .....	142
E.4.4	Master Tool features .....	142
E.5	Securing .....	142
E.5.1	General .....	142
E.5.2	DefaultValues for FSP .....	143
E.5.3	FSP_Authenticity .....	143
E.5.4	FSP_Protocol .....	143
E.5.5	FSP_IO_Description .....	144
E.5.6	Sample serialization for FSP_ParamDescCRC .....	144
E.5.7	FST and FSP parameters and Data Storage .....	145
E.5.8	Sample IODD of an FS-Device.....	145
Annex F (normative)	Device Tool Interface (DTI) for SDCI .....	156
F.1	Purpose of DTI.....	156
F.2	Base model.....	156
F.3	Invocation interface.....	157
F.3.1	Overview .....	157
F.3.2	Detection of Device Tool.....	158
F.3.3	Program Interface Description – PID.....	161
F.3.4	Temporary Parameter File – TPF .....	164
F.3.5	Temporary Backchannel File – TBF .....	169
F.3.6	Temporary Acknowledgment File – TAF .....	171
F.3.7	Invocation behavior .....	171
F.4	Device data objects (DDO).....	172
F.4.1	General .....	172
F.4.2	Structure of DDO package .....	173
F.5	Communication Interface .....	173
F.5.1	General .....	173
F.5.2	Principle of DTI communications.....	174
F.5.3	Gateways .....	175
F.5.4	Configuration of the Communication Server .....	175
F.5.5	Definition of the Communication Interface.....	176
F.5.6	Sequence for establishing a communication relation.....	176
F.5.7	Usage of the Communication Server in stand-alone mode .....	177
F.5.8	SDCI specifics .....	178
F.5.9	Changing communication settings.....	178
F.6	Reaction on incorrect Tool behavior.....	179
F.7	Compatibility .....	179
F.7.1	Schema validation .....	179
F.7.2	Version policy .....	180
F.8	Scalability .....	180
F.8.1	Scalability of a Device Tool.....	180
F.8.2	Scalability of a Master Tool.....	181
F.8.3	Interactions at conformance class combinations .....	181
F.9	Schema definitions.....	181
F.9.1	General .....	181
F.9.2	Schema of the PID.....	181
F.9.3	Schema of the TPF .....	183
F.9.4	Schema of the TBF .....	185
F.9.5	Schema of the TAF .....	186

F.9.6	Schema of DTI primitives .....	187
Annex G (normative)	Main scenarios of SDCI-FS .....	189
G.1	Overview .....	189
G.2	Sequence chart of commissioning .....	190
G.3	Sequence chart of replacement .....	191
G.4	Sequence chart of misconnection .....	192
Annex H (normative)	System requirements .....	193
H.1	Indicators .....	193
H.1.1	General .....	193
H.1.2	OSSDe .....	193
H.1.3	Safety communication .....	193
H.1.4	Acknowledgment request .....	193
H.2	Installation guidelines, electrical safety, and security .....	193
H.3	Safety function response time .....	194
H.4	Duration of demands .....	194
H.5	Maintenance and repair .....	194
H.6	Safety manual .....	194
Annex I (informative)	Information for test and assessment of SDCI-FS components .....	195
Bibliography	.....	196
Figure 1	– Positioning of SDCI-FS in functional safety automation .....	14
Figure 2	– Relationship of this document to standards .....	16
Figure 3	– Memory and transmission octet order .....	25
Figure 4	– SDCI-FS communication layer model .....	25
Figure 5	– Port interface extensions for SDCI-FS .....	26
Figure 6	– Migration to SDCI-FS .....	27
Figure 7	– Minimized paradigm shift from FS-DI to FS-Master .....	28
Figure 8	– FS-Master types and feature levels .....	28
Figure 9	– Original pin layout of SDCI (port class A) .....	29
Figure 10	– Optimized OSSDe commissioning with FS-Master .....	30
Figure 11	– Level "d" of an FS-Master (Class B) .....	31
Figure 12	– Off-site configuration and parameterization .....	31
Figure 13	– SDCI-FS within the automation hierarchy .....	33
Figure 14	– The SDCI physical layer of an FS-Master (class A) .....	36
Figure 15	– The physical layer of an FS-Device (class A) .....	36
Figure 16	– Cross compatibility OSSD and OSSDe .....	37
Figure 17	– Principle OSSDe function .....	38
Figure 18	– Test pulses to detect cross connection faults .....	39
Figure 19	– OSSD timings .....	40
Figure 20	– Typical start-up of an OSSD sensor .....	40
Figure 21	– Start-up of an FS-Device .....	40
Figure 22	– Switching thresholds for FS-Device and FS-Master receivers .....	41
Figure 23	– Reference schematics (one OSSDe channel) .....	42
Figure 24	– Voltage level definitions .....	42
Figure 25	– Charge capability at power-up .....	45

Figure 26 – OSSDe input filter conflict resolution .....	45
Figure 27 – Start-up of an FS-Device .....	46
Figure 28 – Required fast start-up timings .....	46
Figure 29 – State machine of the FS-Master DL-mode handler .....	48
Figure 30 – State machine of the FS-Device DL-mode handler .....	50
Figure 31 – Extension to the Configuration Manager (VerifyRecord) .....	51
Figure 32 – Principle architecture of the FS-Device .....	53
Figure 33 – The FS-Device model .....	54
Figure 34 – Principle architecture of the FS-Master .....	56
Figure 35 – SMI service extensions .....	58
Figure 36 – FSP parameter use cases .....	70
Figure 37 – PDE Splitter .....	73
Figure 38 – PDE Composer .....	74
Figure 39 – Positioning of the SDCI-FS Safety Communication Layer (SCL) .....	76
Figure 40 – FS-Master Safety Communication Layer services .....	76
Figure 41 – FS-Device Safety Communication Layer services .....	78
Figure 42 – Protocol phases to consider .....	79
Figure 43 – Safety PDUs of FS-Master and FS-Device .....	80
Figure 44 – The 1 % share rule of IEC 61784-3:2021 .....	83
Figure 45 – SCL state machine of the FS-Master .....	86
Figure 46 – SCL state machine of the FS-Device .....	89
Figure 47 – FS-Master and FS-Device both with power ON .....	92
Figure 48 – FS-Master power OFF → ON .....	93
Figure 49 – FS-Device with delayed SCL start .....	94
Figure 50 – FS-Device with power OFF and ON .....	95
Figure 51 – FS-Master detects CRC signature error .....	96
Figure 52 – FS-Device detects CRC signature error .....	97
Figure 53 – Monitoring of the SCL cycle time .....	98
Figure 54 – Parameter types and assignments .....	102
Figure 55 – FSCP-Host-centric system .....	103
Figure 56 – Structure of the FSP_VerifyRecord .....	105
Figure 57 – Start-up of SDCI-FS .....	106
Figure 58 – Securing of FST parameters via dedicated tool .....	107
Figure 59 – Modification of FST parameters via Device Tool .....	108
Figure 60 – Creation of FSP and FST parameters .....	109
Figure 61 – Example of a communication hierarchy .....	110
Figure 62 – Motivation for Port selective passivation .....	111
Figure 63 – Qualifier handler (communication) .....	112
Figure 64 – Qualifier handler (OSSDe) .....	112
Figure 65 – Qualifier behavior per FS-Master port .....	113
Figure 66 – Mapping efficiency issues .....	114
Figure A.1 – Instance of an FS I/O data description .....	118
Figure A.2 – Example FS I/O data structure with non-safety data .....	119

Figure A.3 – Securing of safety parameters .....	120
Figure C.1 – Example of a BooleanT data structure .....	124
Figure C.2 – Safety Code of an output message .....	125
Figure C.3 – Safety Code of an input message .....	125
Figure D.1 – CRC-16 generator polynomial.....	127
Figure D.2 – CRC-32 generator polynomial.....	127
Figure D.3 – Bit shift algorithm in "C" language (16 bit).....	128
Figure D.4 – CRC-16 signature calculation using a lookup table .....	128
Figure D.5 – Bit shift algorithm in "C" language (32 bit).....	130
Figure D.6 – CRC-32 signature calculation using a lookup table .....	130
Figure E.1 – Algorithm to build the FSP parameter CRC signatures .....	143
Figure F.1 – Principle of DTI invocation interface .....	157
Figure F.2 – Structure of the registry .....	158
Figure F.3 – Example of a DTI registry.....	159
Figure F.4 – Detection of a Device tool in registry.....	161
Figure F.5 – Menu for Device Tool invocation .....	162
Figure F.6 – Purpose of Device data objects (DDO).....	173
Figure F.7 – Communication routes between Device Tool and Device.....	174
Figure F.8 – Routing across networks and SDCI .....	174
Figure F.9 – Communication Server .....	175
Figure F.10 – Sequence chart for establishing communication .....	176
Figure F.11 – Create Communication Server instance.....	177
Figure F.12 – Example of a Connect Request XML document for SDCI.....	178
Figure F.13 – XML schema of the PID file .....	181
Figure F.14 – XML schema of the TPF .....	183
Figure F.15 – XML schema of a TBF .....	185
Figure G.1 – Commissioning with test and armed operation .....	191
Figure G.2 – FS-Device replacement .....	192
Figure G.3 – FS-Device misconnection .....	192
Table 1 – Operational modes of feature level "a" to "c" (port class A).....	30
Table 2 – Interoperability matrix of safety devices.....	32
Table 3 – PL_Ready .....	36
Table 4 – OSSD states and conditions .....	38
Table 5 – Cross connection faults .....	39
Table 6 – Electric characteristics of a receiver .....	41
Table 7 – Electric and dynamic characteristics of the FS-Device (OSSDe).....	43
Table 8 – Electric and dynamic characteristics of the Port interface .....	44
Table 9 – Cable characteristics .....	47
Table 10 – State transition tables of the FS-Master DL-mode handler .....	49
Table 11 – State transition tables of the FS-Device DL-mode handler .....	50
Table 12 – State transition tables of the Configuration Manager .....	52
Table 13 – Extension to Data Storage (DS) state machine .....	55

Table 14 – Data Storage Backup Levels .....	55
Table 15 – SMI services used for FS-Master.....	57
Table 16 – SMI_FSMasterAccess .....	59
Table 17 – SMI_FSPDInOut.....	61
Table 18 – ArgBlock types and ArgBlockIDs .....	62
Table 19 – FSMasterAccess .....	63
Table 20 – FSCPAuthenticity .....	63
Table 21 – FSPortConfigList.....	64
Table 22 – FSPortStatusList .....	66
Table 23 – SPDUIIn .....	67
Table 24 – SPDUIOut .....	68
Table 25 – FSPDInOut.....	68
Table 26 – Use case reference table.....	70
Table 27 – Communication errors and safety measures .....	75
Table 28 – SCL services of FS-Master .....	77
Table 29 – SCL services of FS-Device.....	78
Table 30 – Protocol phases to consider .....	80
Table 31 – Control and counting (Control&MCnt) .....	81
Table 32 – Status and counting mirror (Status&DCnt).....	81
Table 33 – MCount and DCount_i values .....	82
Table 34 – FS process I/O data types .....	84
Table 35 – Rules for the layout of values and qualifiers .....	84
Table 36 – Order of values and qualifier .....	85
Table 37 – Definition of terms used in SCL state machine of the FS-Master.....	86
Table 38 – FS-Master SCL states and transitions .....	87
Table 39 – Definition of terms used in SCL state machine of the FS-Device.....	89
Table 40 – FS-Device SCL states and transitions .....	90
Table 41 – Timing constraints .....	98
Table 42 – Qualifier bits "GOOD/BAD" .....	112
Table 43 – State transition Table for the qualifier behavior.....	113
Table A.1 – Indices for SDCI-FS .....	115
Table A.2 – Coding of protocol version .....	117
Table A.3 – Coding of protocol mode .....	117
Table A.4 – Generic FS I/O data structure description.....	118
Table B.1 – FS-Device SCL specific EventCodes.....	121
Table B.2 – FS-Master SCL specific EventCodes.....	122
Table C.1 – Data types for SDCI-FS .....	123
Table C.2 – BooleanT for SDCI-FS .....	123
Table C.3 – Example of BooleanT within a RecordT.....	123
Table C.4 – IntegerT(16).....	124
Table C.5 – IntegerT(16) coding .....	124
Table C.6 – IntegerT(32).....	125
Table C.7 – IntegerT(32) coding .....	125

Table D.1 – CRC generator polynomials for SDCI-FS ..... 126

Table D.2 – Definition of variables used in Figure D.3..... 128

Table D.3 – Definition of variables used in Figure D.4..... 129

Table D.4 – Lookup Table for CRC-16 signature calculation ..... 129

Table D.5 – Definition of variables used in Figure D.5..... 130

Table D.6 – Definition of variables used in Figure D.4..... 130

Table D.7 – Lookup Table for CRC-32 signature calculation ..... 131

Table E.1 – Specific behavior of FS-Device "Reset" SystemCommands..... 141

Table E.2 – User actions to replace DefaultValues..... 143

Table E.3 – RecordItems of FSP\_Protocol where allowed values shall be serialized ..... 144

Table E.4 – Sample serialization for FSP\_ParamDescCRC..... 144

Table F.1 – Description of PID file elements ..... 162

Table F.2 – Elements of a TPF ..... 165

Table F.3 – Elements of the TBF..... 170

Table F.4 – Elements of the TAF..... 171

Table F.5 – Invocation cases and behaviors ..... 172

Table F.6 – Communication Schema mapping ..... 178

Table F.7 – Reaction on incorrect Tool behavior ..... 179

Table F.8 – DTI conformance classes ..... 180

Table F.9 – DTI feature levels of Device Tools..... 180

Table F.10 – Interactions at conformance class combinations ..... 181

Table G.1 – Main scenarios of SDCI-FS..... 189

## INTERNATIONAL ELECTROTECHNICAL COMMISSION

---

**INDUSTRIAL NETWORKS –  
SINGLE-DROP DIGITAL COMMUNICATION INTERFACE –**
**Part 2: Functional safety extensions****FOREWORD**

- 1) The International Electrotechnical Commission (IEC) is a worldwide organization for standardization comprising all national electrotechnical committees (IEC National Committees). The object of IEC is to promote international co-operation on all questions concerning standardization in the electrical and electronic fields. To this end and in addition to other activities, IEC publishes International Standards, Technical Specifications, Technical Reports, Publicly Available Specifications (PAS) and Guides (hereafter referred to as "IEC Publication(s)"). Their preparation is entrusted to technical committees; any IEC National Committee interested in the subject dealt with may participate in this preparatory work. International, governmental and non-governmental organizations liaising with the IEC also participate in this preparation. IEC collaborates closely with the International Organization for Standardization (ISO) in accordance with conditions determined by agreement between the two organizations.
- 2) The formal decisions or agreements of IEC on technical matters express, as nearly as possible, an international consensus of opinion on the relevant subjects since each technical committee has representation from all interested IEC National Committees.
- 3) IEC Publications have the form of recommendations for international use and are accepted by IEC National Committees in that sense. While all reasonable efforts are made to ensure that the technical content of IEC Publications is accurate, IEC cannot be held responsible for the way in which they are used or for any misinterpretation by any end user.
- 4) In order to promote international uniformity, IEC National Committees undertake to apply IEC Publications transparently to the maximum extent possible in their national and regional publications. Any divergence between any IEC Publication and the corresponding national or regional publication shall be clearly indicated in the latter.
- 5) IEC itself does not provide any attestation of conformity. Independent certification bodies provide conformity assessment services and, in some areas, access to IEC marks of conformity. IEC is not responsible for any services carried out by independent certification bodies.
- 6) All users should ensure that they have the latest edition of this publication.
- 7) No liability shall attach to IEC or its directors, employees, servants or agents including individual experts and members of its technical committees and IEC National Committees for any personal injury, property damage or other damage of any nature whatsoever, whether direct or indirect, or for costs (including legal fees) and expenses arising out of the publication, use of, or reliance upon, this IEC Publication or any other IEC Publications.
- 8) Attention is drawn to the Normative references cited in this publication. Use of the referenced publications is indispensable for the correct application of this publication.
- 9) Attention is drawn to the possibility that some of the elements of this IEC Publication may be the subject of patent rights. IEC shall not be held responsible for identifying any or all such patent rights.

IEC 61139-2 has been prepared by subcommittee 65C: Industrial networks, of IEC technical committee TC65: Industrial-process measurement, control and automation. It is an International Standard.

The text of this International Standard is based on the following documents:

Draft	Report on voting
65C/1168/FDIS	65C/1174/RVD

Full information on the voting for its approval can be found in the report on voting indicated in the above table.

The language used for the development of this International Standard is English.

This document was drafted in accordance with ISO/IEC Directives, Part 2, and developed in accordance with ISO/IEC Directives, Part 1 and ISO/IEC Directives, IEC Supplement, available at [www.iec.ch/members\\_experts/refdocs](http://www.iec.ch/members_experts/refdocs). The main document types developed by IEC are described in greater detail at [www.iec.ch/standardsdev/publications](http://www.iec.ch/standardsdev/publications).

A list of all parts in the IEC 61139 series, published under the general title *Industrial networks – Single-drop digital communication interface*, can be found on the IEC website.

The committee has decided that the contents of this document will remain unchanged until the stability date indicated on the IEC website under [webstore.iec.ch](http://webstore.iec.ch) in the data related to the specific document. At this date, the document will be

- reconfirmed,
- withdrawn,
- replaced by a revised edition, or
- amended.

**IMPORTANT – The "colour inside" logo on the cover page of this document indicates that it contains colours which are considered to be useful for the correct understanding of its contents. Users should therefore print this document using a colour printer.**

## INTRODUCTION

The base technology of IO-Link™<sup>1</sup> is subject matter of the international standard IEC 61131-9 being part of a series of standards on programmable controllers and the associated peripherals such as remote I/O (RIO).

It specifies a single-drop digital communication interface technology – named SDCI, which extends the traditional switching input and output interfaces as defined in IEC 61131-2 towards a point-to-point communication link using coded switching. This technology enables the cyclic exchange of digital input and output process data between a Master and its associated Devices (sensors, actuators, I/O terminals, etc.). The Master can be part of a fieldbus communication system or any stand-alone processing unit. The technology also enables the acyclic transfer of parameters to Devices and the propagation of diagnosis information from the Devices to the upper-level automation system (controller, host) via the Master.

Physical topology is point-to-point from each Device to the Master using 3 wires over distances up to 20 m. The SDCI physical interface is backward compatible with the usual 24 V I/O signalling specified in IEC 61131-2 and supports three transmission rates of 4,8 kbit/s, 38,4 kbit/s and 230,4 kbit/s are supported.

The main advantages of the SDCI technology are:

- dual use of either switching signals (DI/DO) or coded switching communication respectively,
- traditional switching sensors and actuators now providing alternatively single drop digital communication within the same Device,
- one thin, robust, very flexible cable without shielding for power supply and signalling,
- lowest-cost digital communication down to the lowest end sensors and actuators.

The functional safety variant of SDCI is called SDCI-FS. Figure 1 shows an example positioning of SDCI-FS in functional safety automation.

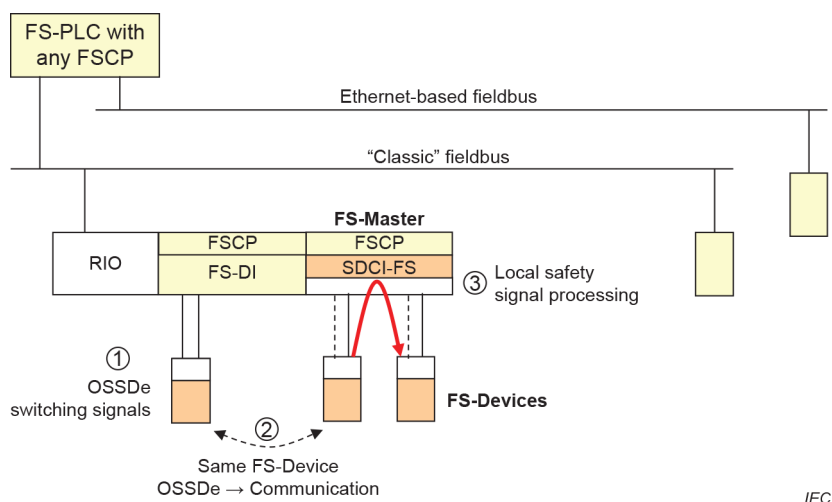

**Figure 1 – Positioning of SDCI-FS in functional safety automation**

<sup>1</sup> IO-Link™ is a trade name of the "IO-Link Community". This information is given for the convenience of users of this specification and does not constitute an endorsement by the IO-Link Community of the trade name holder or any of its products. Compliance to this document does not require use of the registered logos for IO-Link™. Use of the registered logos for IO-Link™ requires permission of the "IO-Link Community".

In this example, a remote I/O is connected to a functional safety programmable controller using one of the FSCPs of the IEC 61784-3 series [1]<sup>2</sup> to communicate with an FS-DI module and a gateway to an SDCI-FS FS-Master. FS-Devices with OSSDe can be connected to FS-DIs or FS-Masters. All FS-Devices can communicate with any FS-Master using the SDCI-FS protocol regardless of the upper-level FSCP-system. The same is true for safety actuators (FS-Devices) such as drives with integrated safety. This means the largest component commonality ① for sensors and actuators similar to the DI and DO interfaces standardized within IEC 61131-2.

Safety sensors with OSSDe interfaces – equipped with SDCI-FS communication – can be parameterized via auxiliary tools such as "USB-Masters", then connected to an FS-DI and operated in OSSDe mode. They also can be operated in OSSDe mode on an FS-Master that supports OSSDe. In case these safety sensors are equipped with SDCI-FS communication in addition, they can be operated in both modes ②, either OSSDe or SDCI-FS. This corresponds to the SDCI SIO paradigm.

The concept of SDCI-FS allows for local safety signal processing if the gateway/FS-Master provides a local safety controller ③.

This document provides the necessary extensions to IEC 61131-9 for functional safety communication including standardization of OSSDe and parameterization within the domain of safety for machinery. Figure 2 shows its relationships to international fieldbus and safety standards as well as to relevant specifications (see Clause 2 and bibliography). Any functional safety starts with risk assessment and risk reduction (ISO 12100). One possibility of risk reduction is the usage of electrical or electronic control systems. For the design of those, standards such as IEC 61508, IEC 62061, and ISO 13849 can be used. Environmental conditions such as EMC are covered by for example IEC 61000-6-7. Further aspects are installations and security issues. A number of product standards such as IEC 60947-5-3 and ISO 14119 complement the generic or sector standards.

---

<sup>2</sup> Numbers in square brackets refer to the Bibliography.

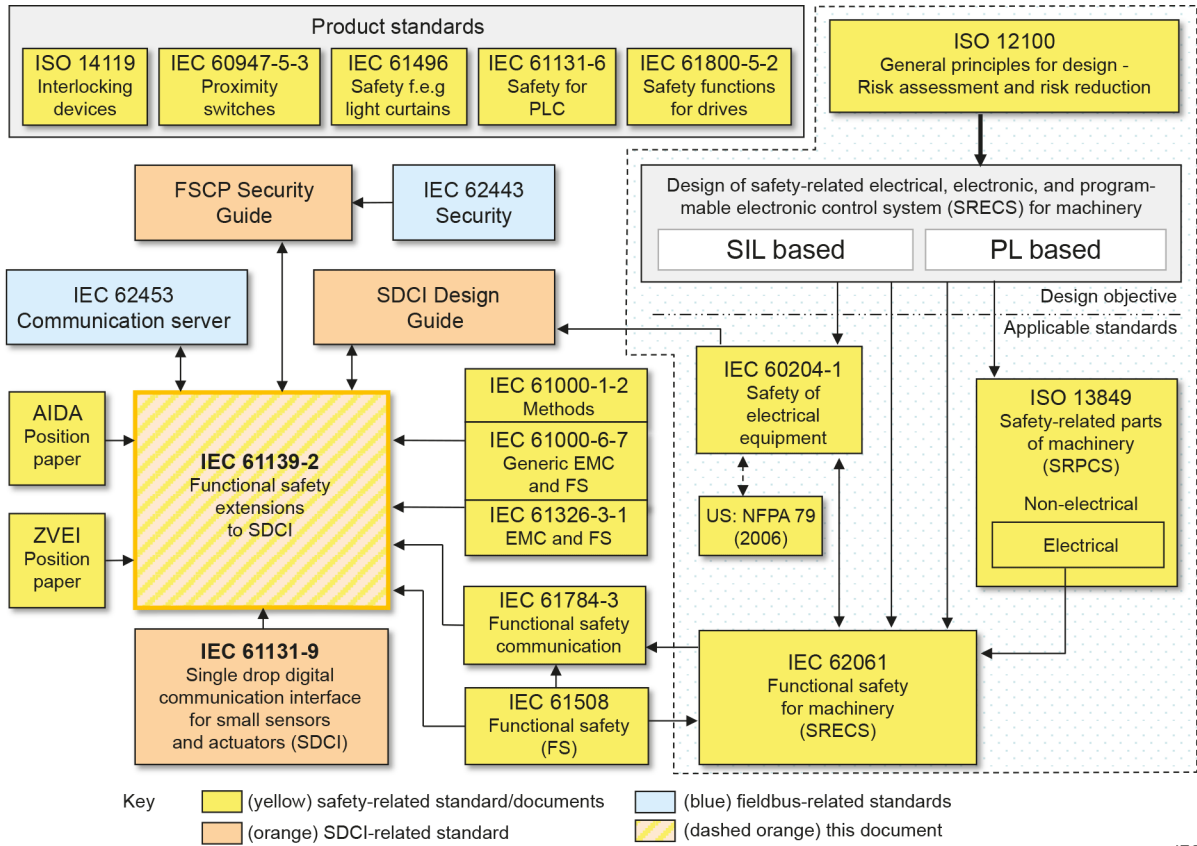

IEC

**Figure 2 – Relationship of this document to standards**

SDCI-FS can be used for functional safety applications according to IEC 62061 and IEC 61508 up to SIL3 and/or according to ISO 13849 up to PLe.

# INDUSTRIAL NETWORKS – SINGLE-DROP DIGITAL COMMUNICATION INTERFACE –

## Part 2: Functional safety extensions

### 1 Scope

This part of IEC 61139 specifies the extensions to SDCI in IEC 61131-9 for functional safety. This comprises:

- a standardized OSSDe interface for redundant switching signals based on IEC 61131-2,
- minor modifications/extensions to state machines of SDCI to support the safety operations,
- a lean functional safety communication protocol on top of the standard SDCI communication which is a black channel according to IEC 61784-3:2021,
- protocol management functions for configuration, parameterization, and commissioning,
- IODD extensions for functional safety,
- a Device tool interface to support Dedicated Tools according to functional safety standards.

This document does not cover:

- communication interfaces or systems including multi-point or multi-drop linkages,
- communication interfaces or systems including multi-channel or encrypted linkages,
- wireless communication interfaces or systems,
- integration of SDCI-FS into upper-level systems such as fieldbuses/FSCPs.

### 2 Normative references

The following documents are referred to in the text in such a way that some or all of their content constitutes requirements of this document. For dated references, only the edition cited applies. For undated references, the latest edition of the referenced document (including any amendments) applies.

IEC 60204-1, *Safety of machinery – Electrical equipment of machines – Part 1: General requirements*

IEC 61010-2-201, *Safety requirements for electrical equipment for measurement, control and laboratory use – Part 2-201: Particular requirements for control equipment*

IEC 61131-2, *Industrial-process measurement and control – Programmable controllers – Part 2: Equipment requirements and tests*

IEC 61131-9:—<sup>3</sup>, *Programmable controllers – Part 9: Single-drop digital communication interface for small sensors and actuators (SDCI)*

IEC 61496-1, *Safety of machinery – Electro-sensitive protective equipment – Part 1: General requirements and tests*

---

<sup>3</sup> Under preparation. Stage at the time of publication: IEC/CFDIS 61131-9:2022.